



U S A C – Z E R E M

Veronika Fejtová • ADE • I. ročník Bc. • 2021/2022



Minimalistické pouzdro hodinek společně s kovovým řemínkem dává prostor nápadnému barevnému ciferníku, který upoutá pozornost.

Ručky tvoří tři kruhové transparentní barevné folie. Každá ručka nese dvě barvy. „Předěl“ mezi těmito barvami tvoří rovnou linii, která nám ukazuje čas. Hodinky využívají postupného překrývání ruček, díky kterému vznikají další barvy a ciferník tak mění každou vteřinu svůj vzhled.

FFCATHONA

3

transparentní
folie

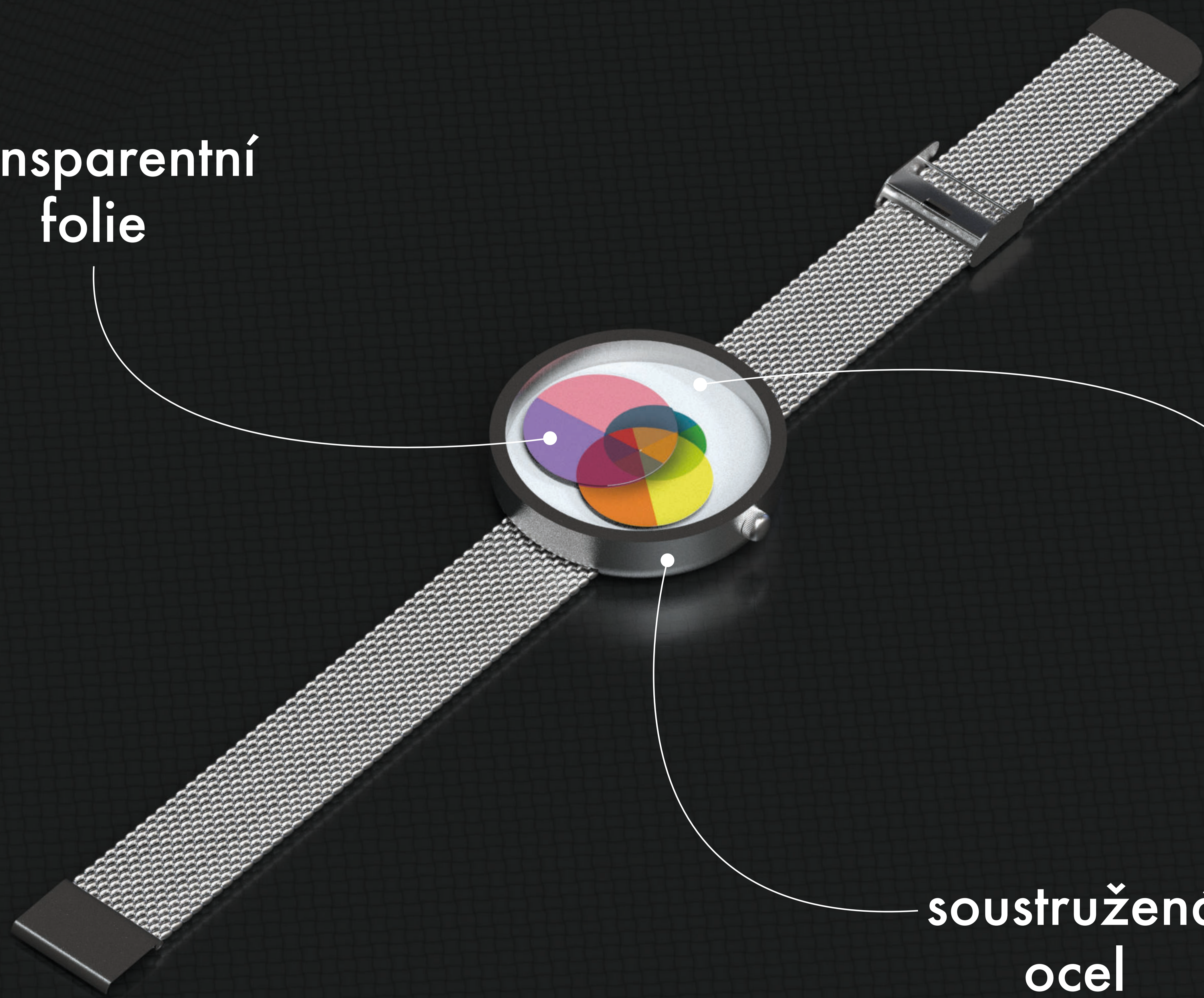

sklo

soustružená
ocel

M
A
T
E
R
I
Á
L
Y

15:00:45

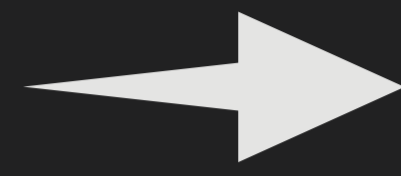

12:00:00

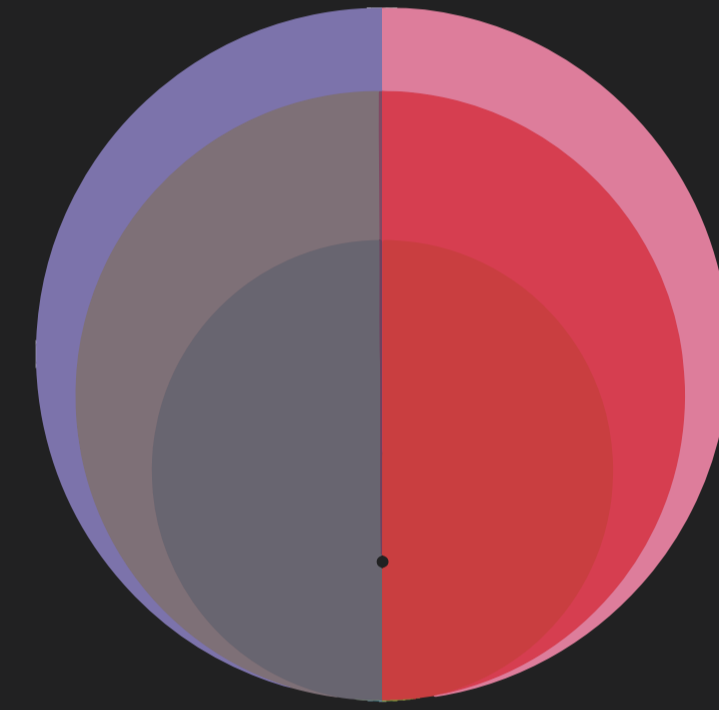

18:00:34

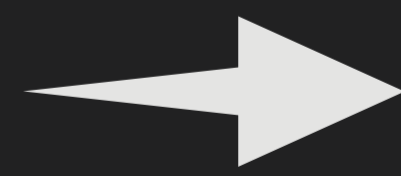
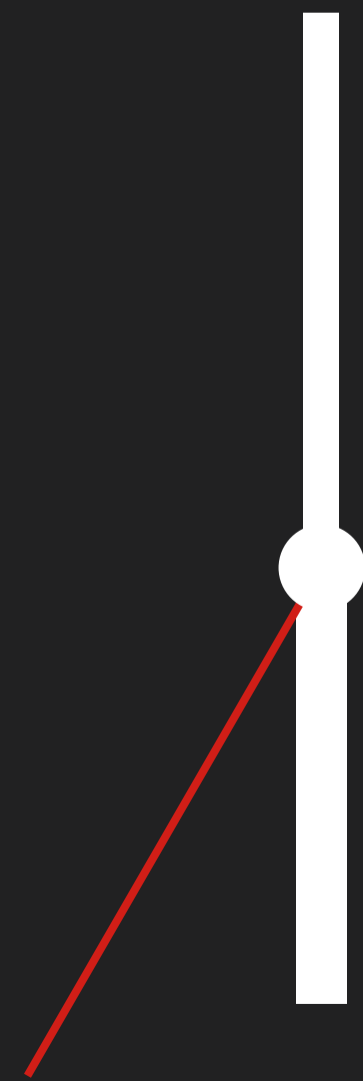
Y
K
Č
U
R

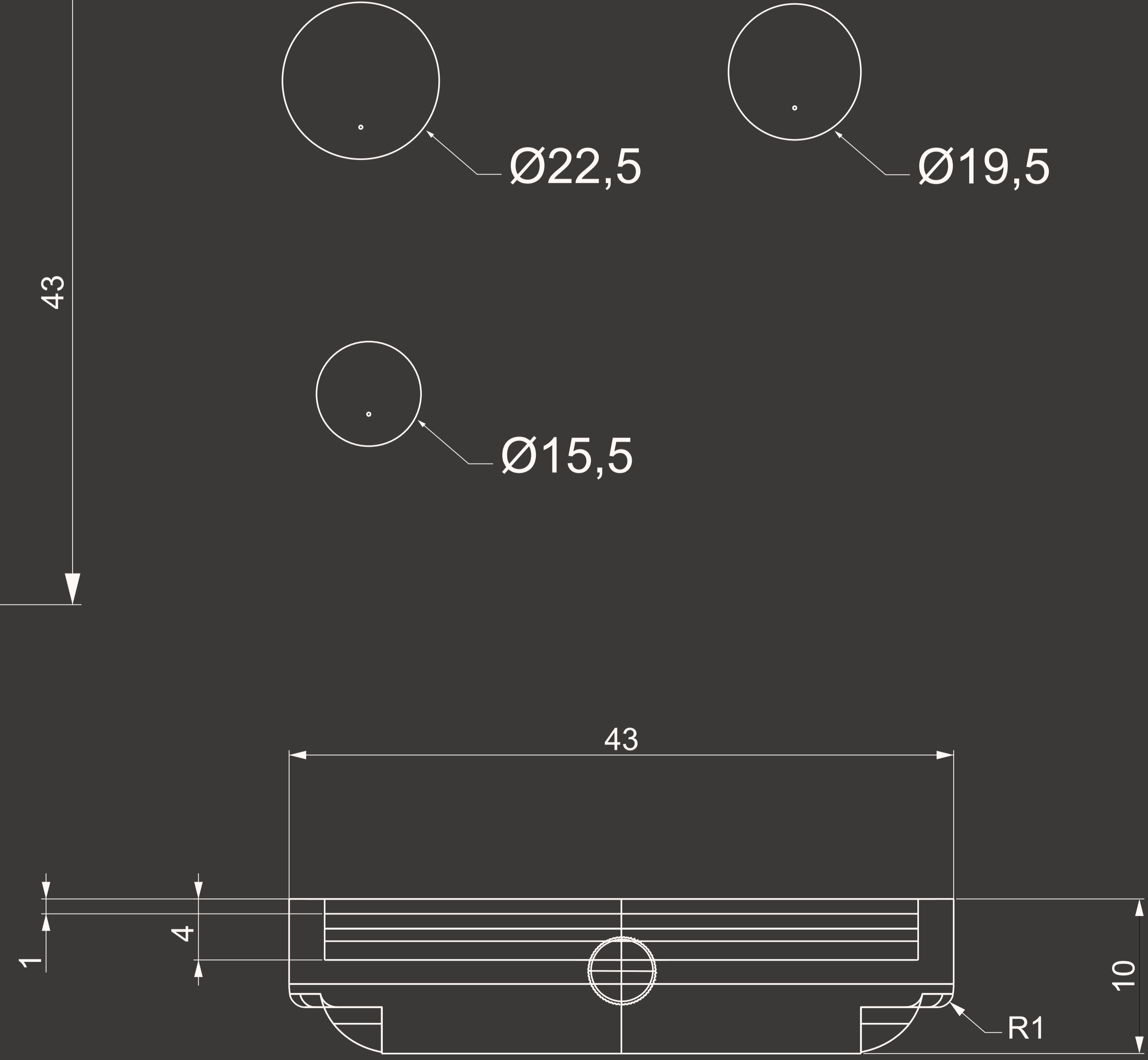
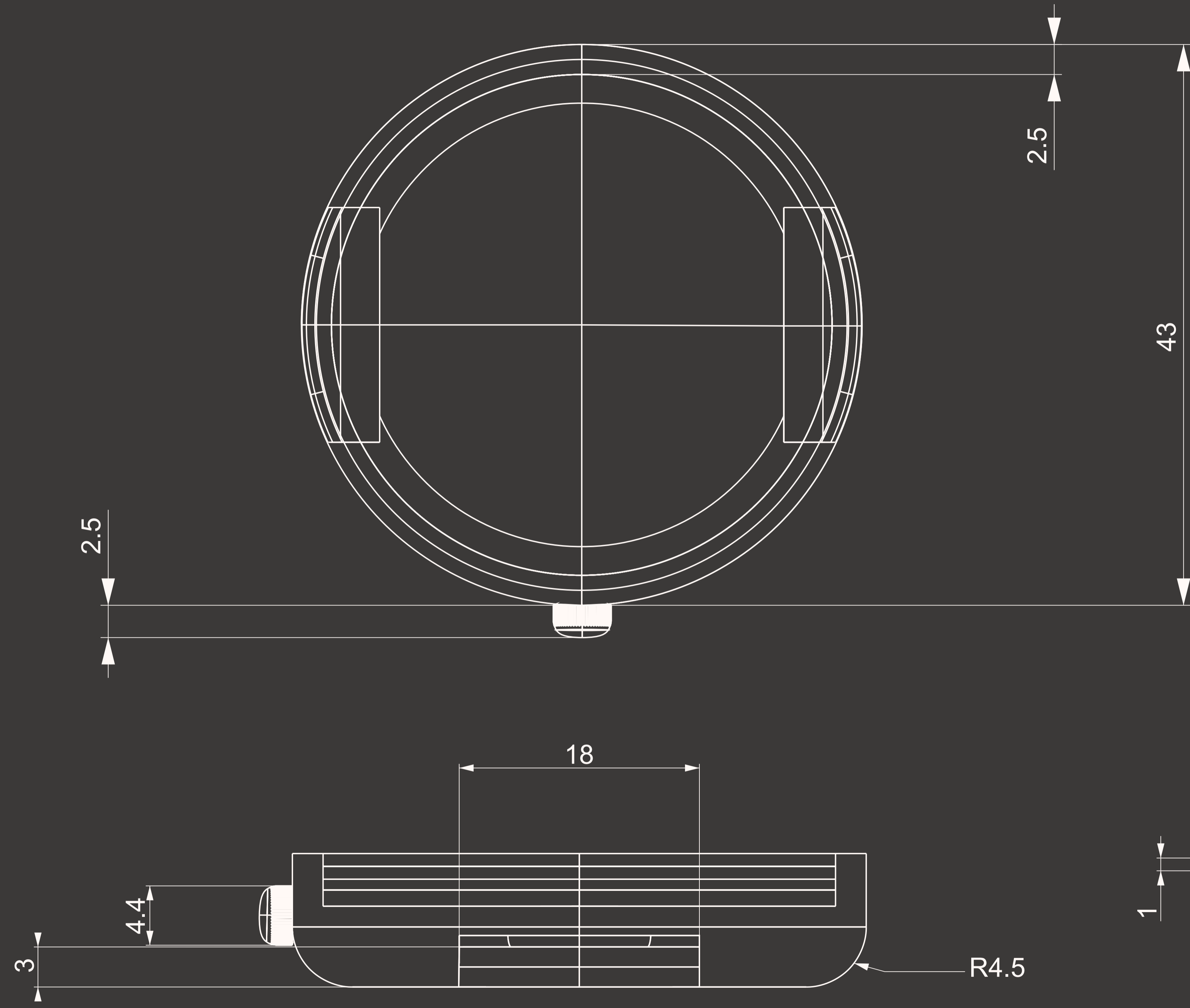

6

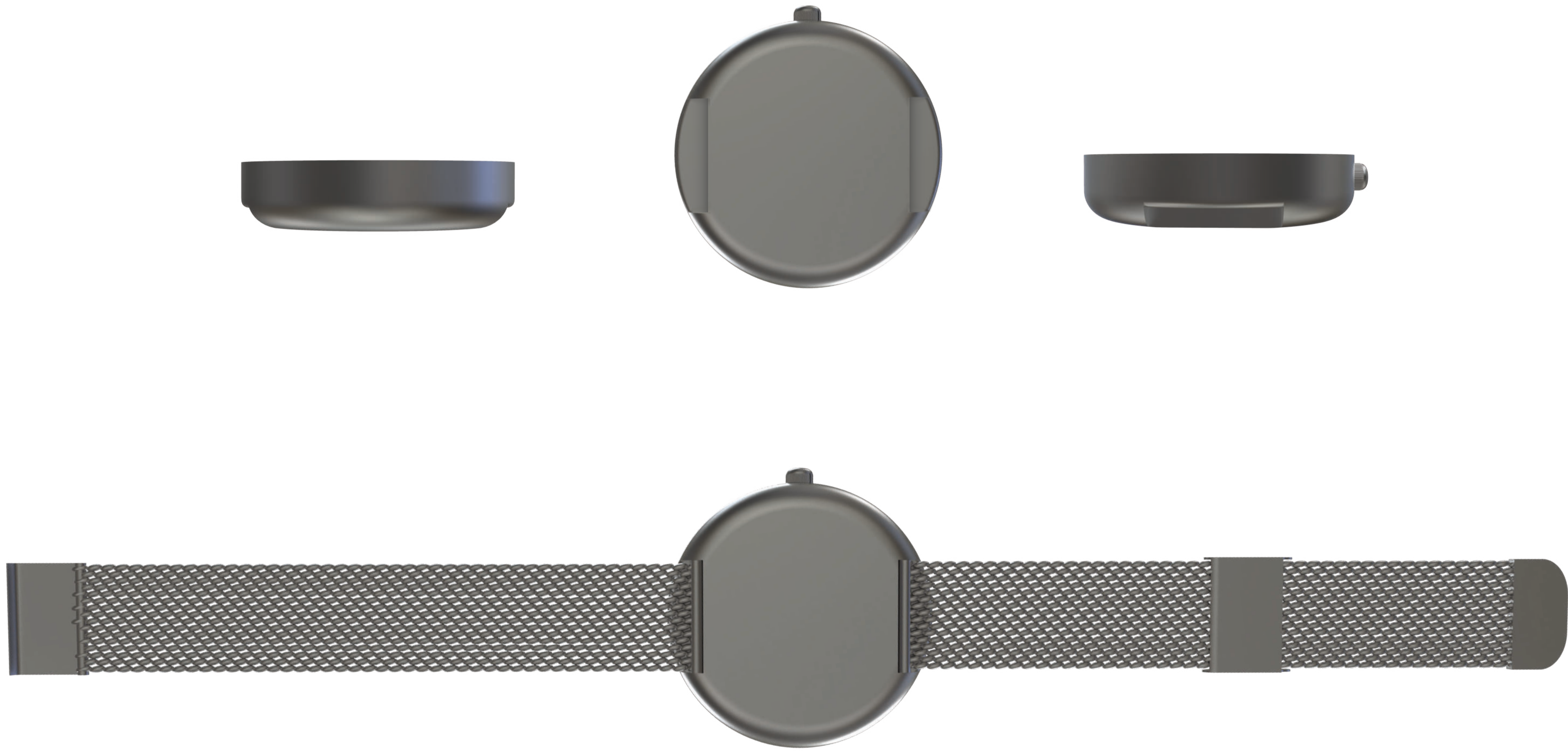

Číslo výrobku: 123456789

7

Barevné ručky



V
A
R
I
A
N
T
Y

Černobílé ručky



V
A
R
I
A
N
T
Y