

VÝSTAVA PTAČÍCH BUDEK

NAPAJEDLA



Semestrální práce LS 2021/22
Výstava ptačích budek Napajedla

vedoucí práce: Ing. arch. Kamil Koláček
zpracovala: Karolína Kocmanová

Konceptem celé této exteriérové expozice je seznámení veřejnosti se světovou architekturou zpracovanou do podoby ptačích budek. Na náměstí v Napajedlích se tak objeví více či méně známé významné budovy z celého světa. Hlavním důvodem, proč jsem ji umístila právě na náměstí je, aby se s ní mohlo seznámit co největší množství lidí během běžného dne při cestě do školy, zaměstnání a nebo za nákupy či zábavou. Výstava tak může přispět nejen k oživení celého prostoru, ale být i zajímavým zdrojem vědomostí . Stojany představující jednotlivé státy jsou rozmístěny dle přibližné zeměpisné polohy po Masarykově náměstí, na kterém bude křídovým sprejem liniemi naznačená mapa světa. Centrem celého "Napajedelského světa" bude Česká republika. K ní budou ostatní státy orientovány šipkou s udanou vzdáleností v km . Každý stojan je originální. Konstrukce je přizpůsobena daným budkám, které zde budou zavěšeny.

Materiálové řešení stojanů: žlutě lakovaná konstrukce z ocelových tyčí v kombinaci s modřínovým dřevem.

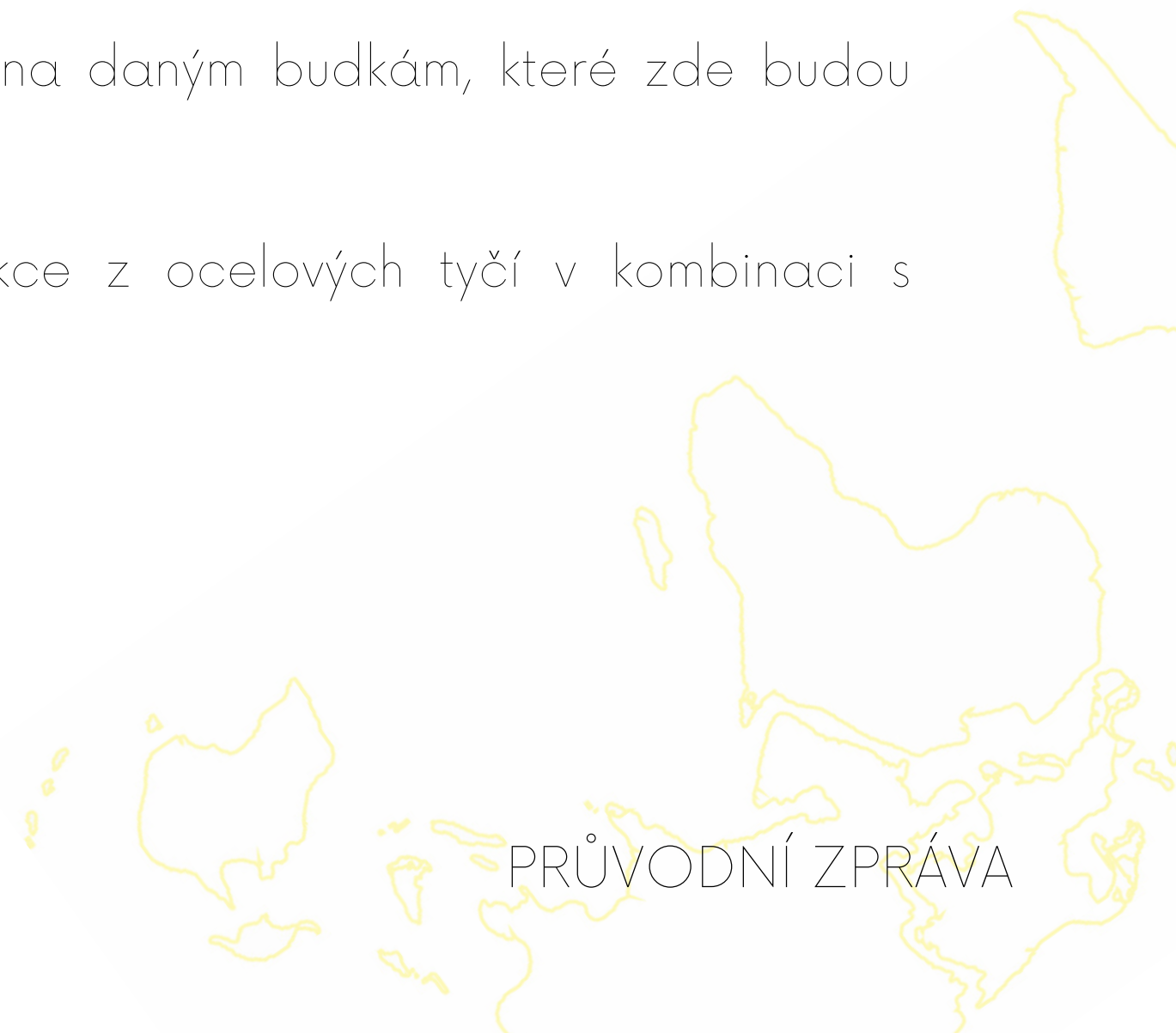

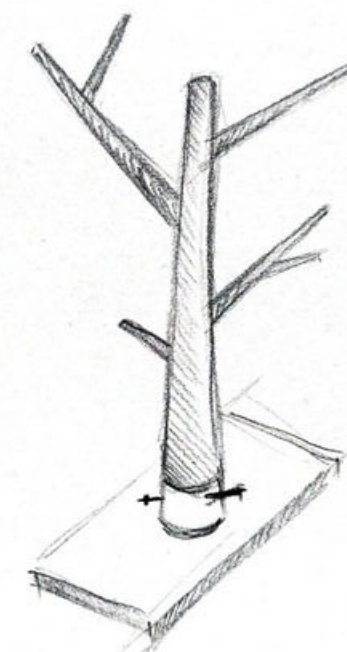
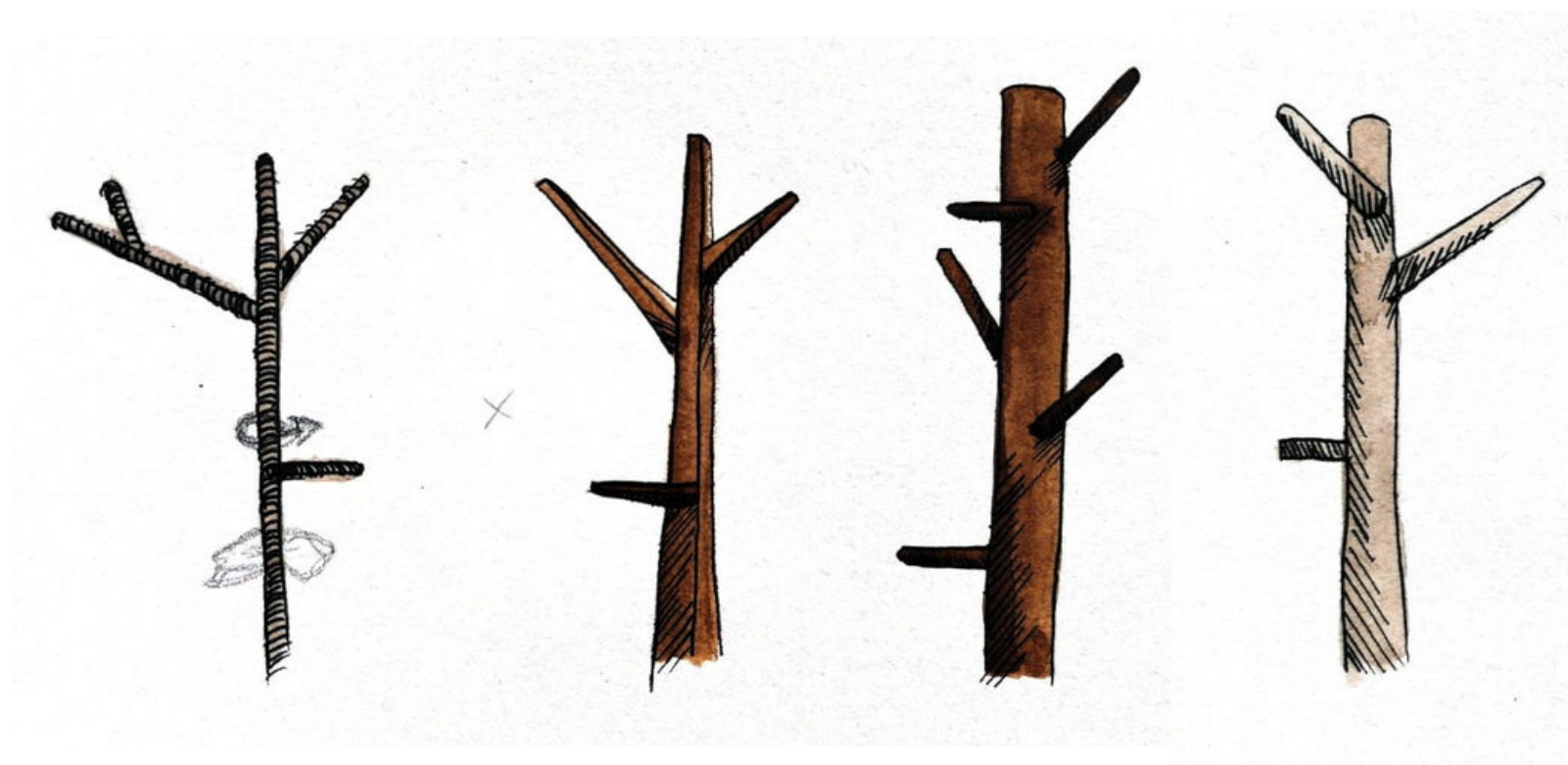
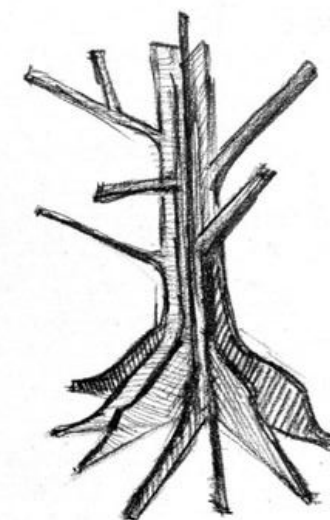
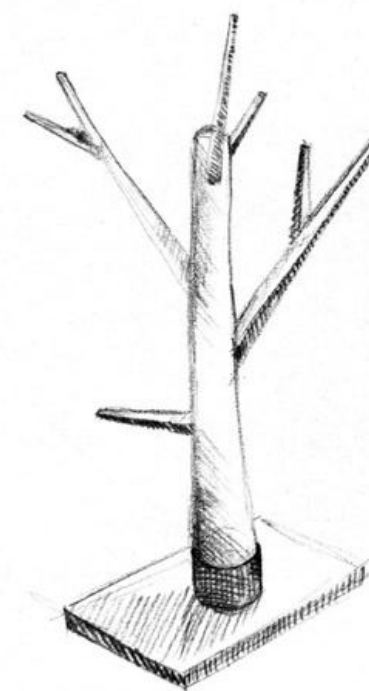
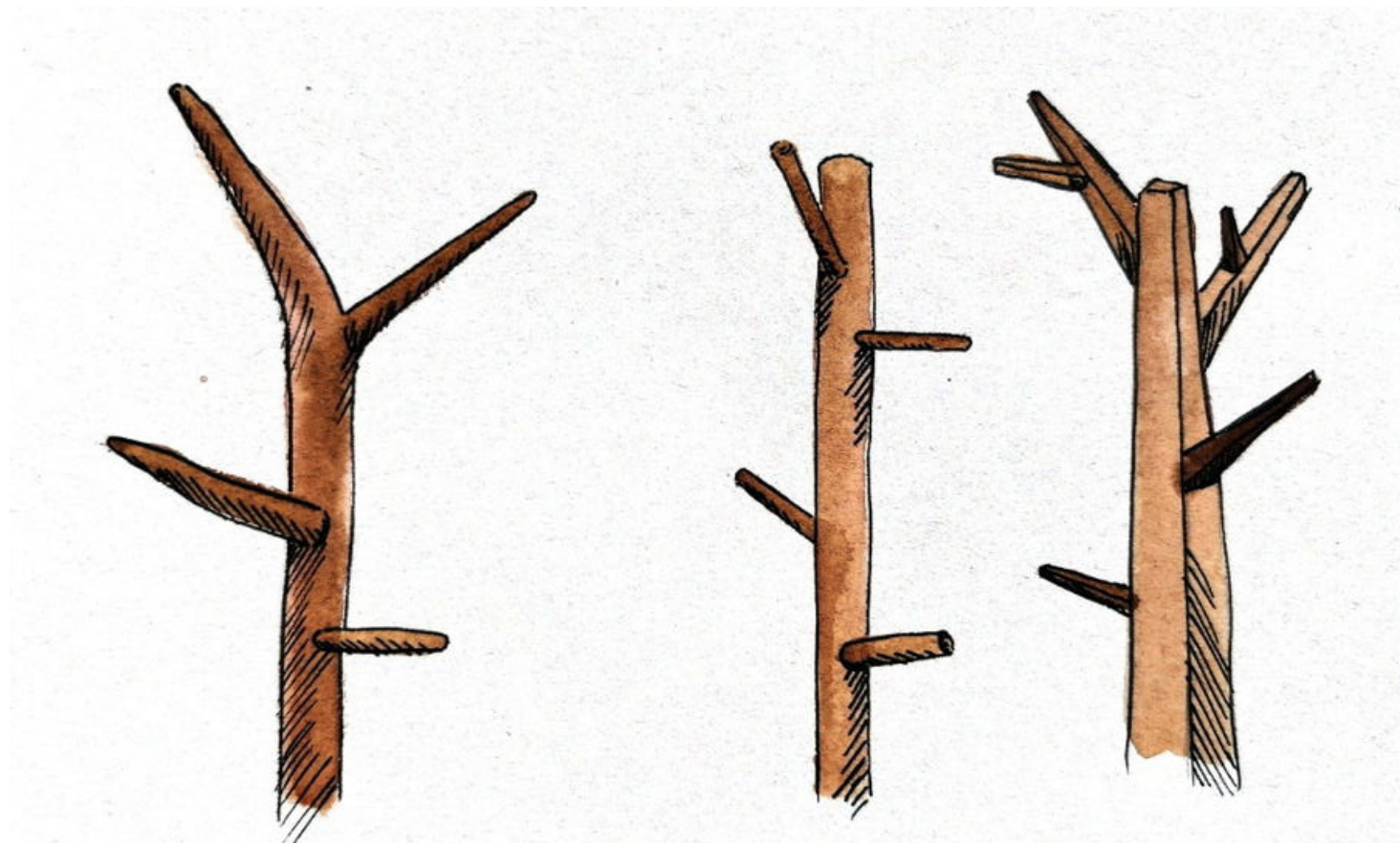

PRŮBĚH HLEDÁNÍ FINÁLNÍ PODOBY - SKICI

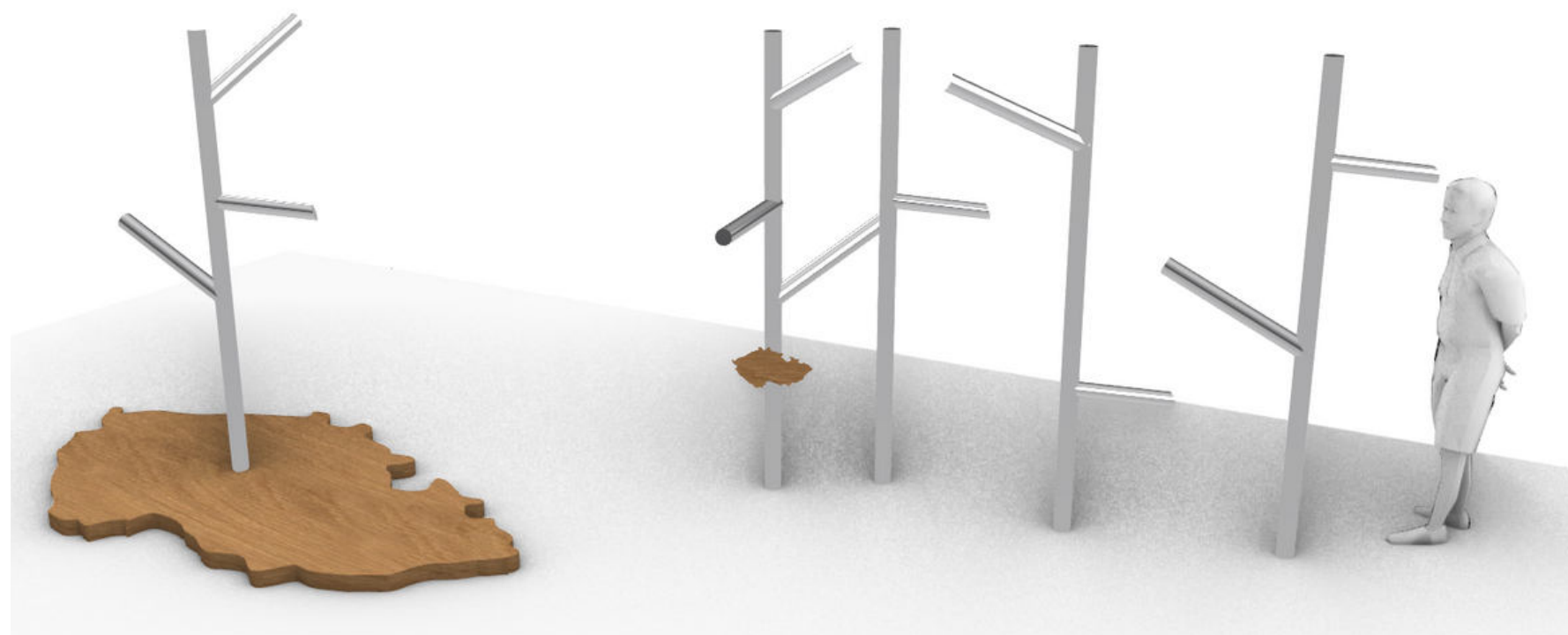
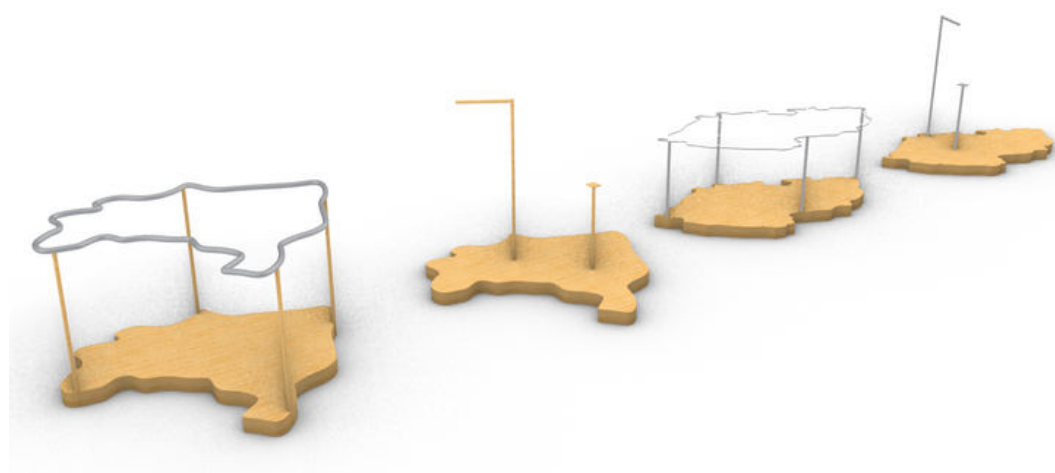
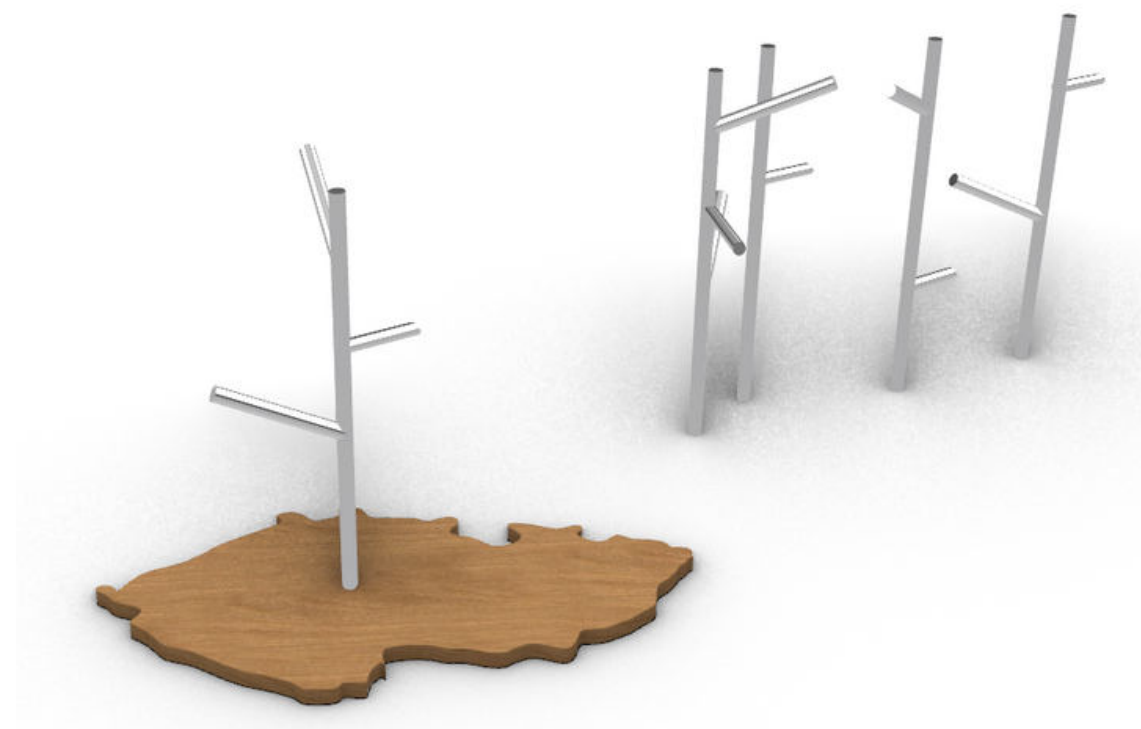
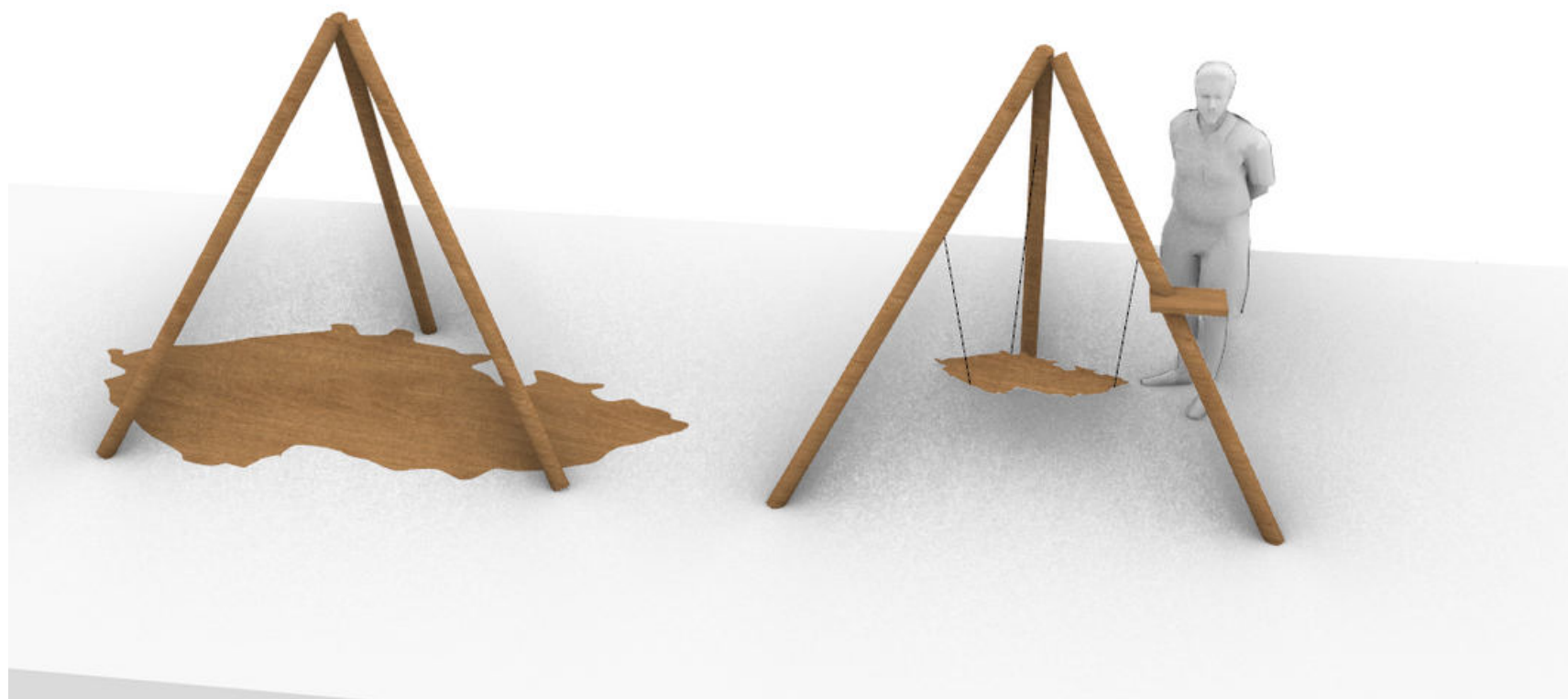

PRŮBĚH HLEDÁNÍ FINÁLNÍ PODOBY - STOJANY



PRŮBĚH HLEDÁNÍ FINÁLNÍ PODOBY - MODELY



SITUAČNÍ PLÁNEK – MASARYKOVO NÁMĚSTÍ



Mapa světa nakreslená na
dlažbě náměstí
- křídový značkovací sprej

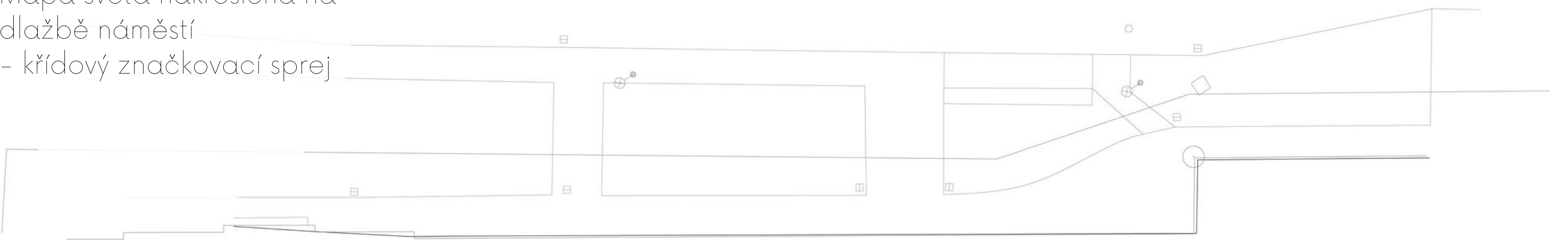

PŮDORYS NÁMĚSTÍ + ROZMÍSTĚNÍ STOJANŮ



ČESKÁ REPUBLIKA

vzducholod' Gulliver, DOX Praha (M. Rajniš)

Prior, Pardubice

Vysílač Ještěd, Liberec (K. Hubáček)

Knihovna chobotnice, Praha (J. Kaplický)

SLOVENSKO

Skanzen Čičmany

VELKÁ BRITÁNIE

Riverside museum, Glasgow, Skotsko (Z. Hadid)

Katedrála Panny Marie, Salisbury

Novinářská tribuna na stadionu, Londýn

Midrock house, Skotsko

NORSKO

The Arctic Cathedral

Opera house, Oslo

ARGENTINA

Barevná čtvrť La Boca, Buenos Aires

ŠPANĚLSKO

Museum Dálí, Figures

Hotel a vinařství Marques de Riscal (Frank o Gehry,)

USA

Farnsworth House (Ludwig Mies van der Rohe)

Hearst Tower, NY

The Broad, Grand Avenue, Los Angeles (Renzo Piano)

Guggenheim museum, NY

The Volcano house, Mojave deser, California

JIŽNÍ KOREA

Cultural center Two Moon, Moon Hoon

URUGUAY

Letiště

BRAZÍLIE

Itamaraty place (Oscar Niemeyer)

Katedrála Zjevení Panny Marie, Brasilia (Oscar Niemeyer)

Niterói museum (Oscar Niemeyer)

FRANCIE

Notre Dame, Paříž

Villa Savoye (Le Corbusier)

Arab world institute

Louver, Paříž

SPOJENÉ ARABSKÉ EMIRÁTY

Mosque, Dubai (Maria Yasko a Nikita Tikhonov)

Hotel Burdž al Arab, Dubaj

ŘECKO

Chrám Athény Niké

EGYPT

Pyramidy

JORDÁNSKO

Skalní chrám



STÁTŮ, STAVBY

ČESKÁ REPUBLIKA

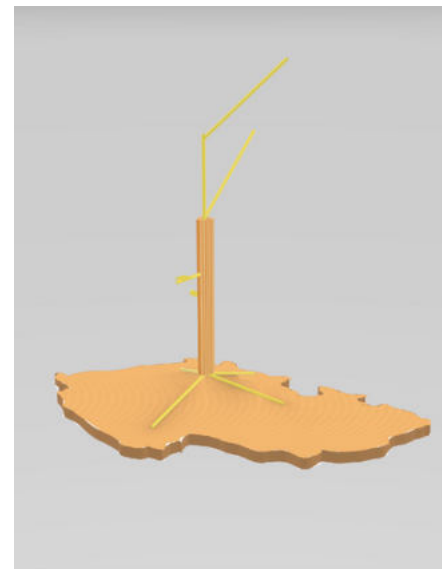
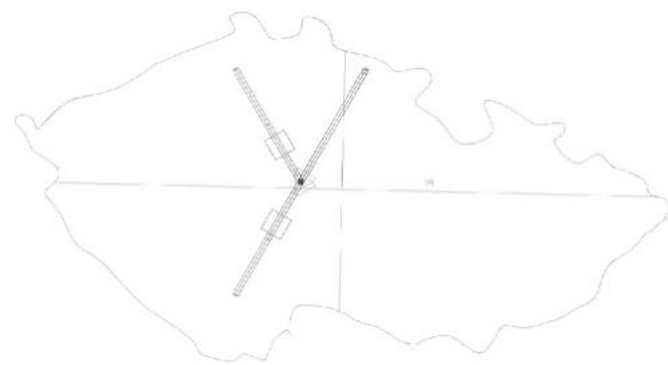
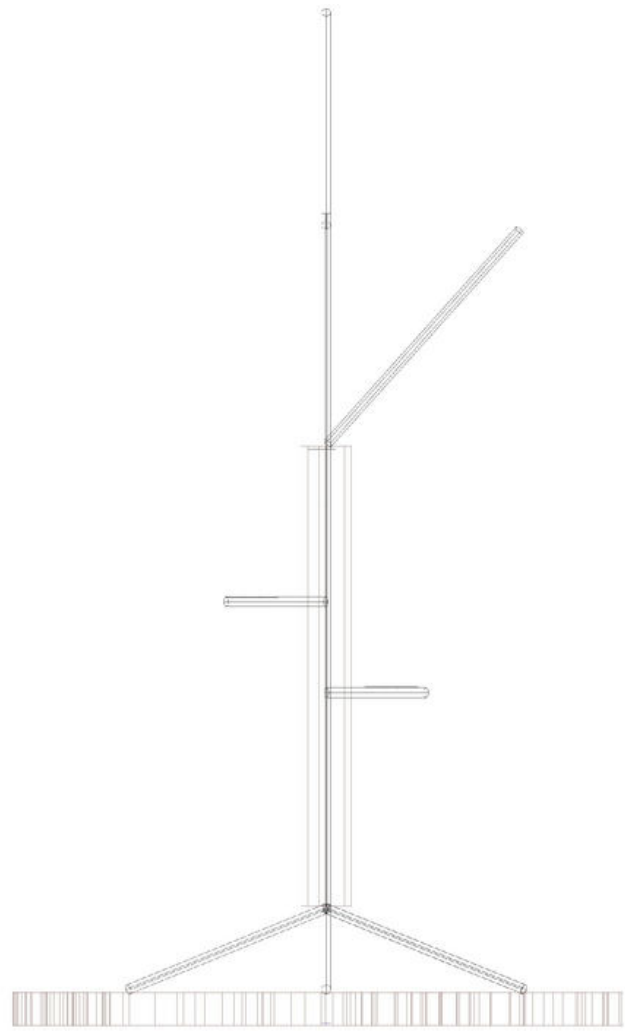

SLOVENSKO (348 km)

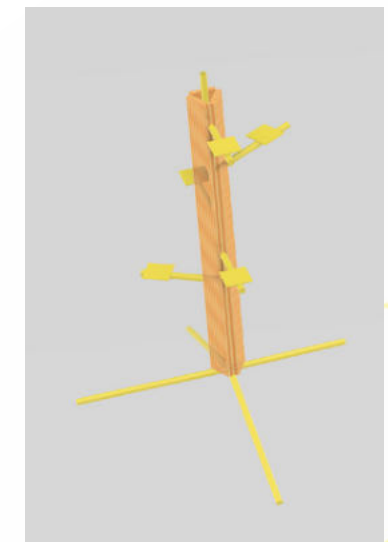
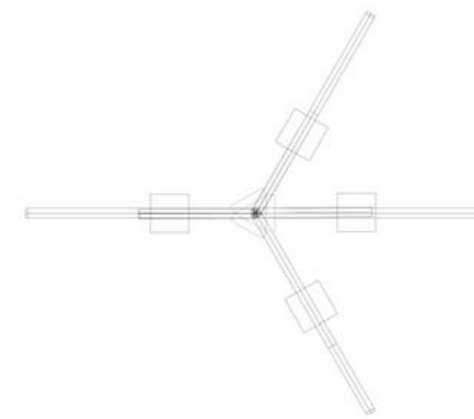
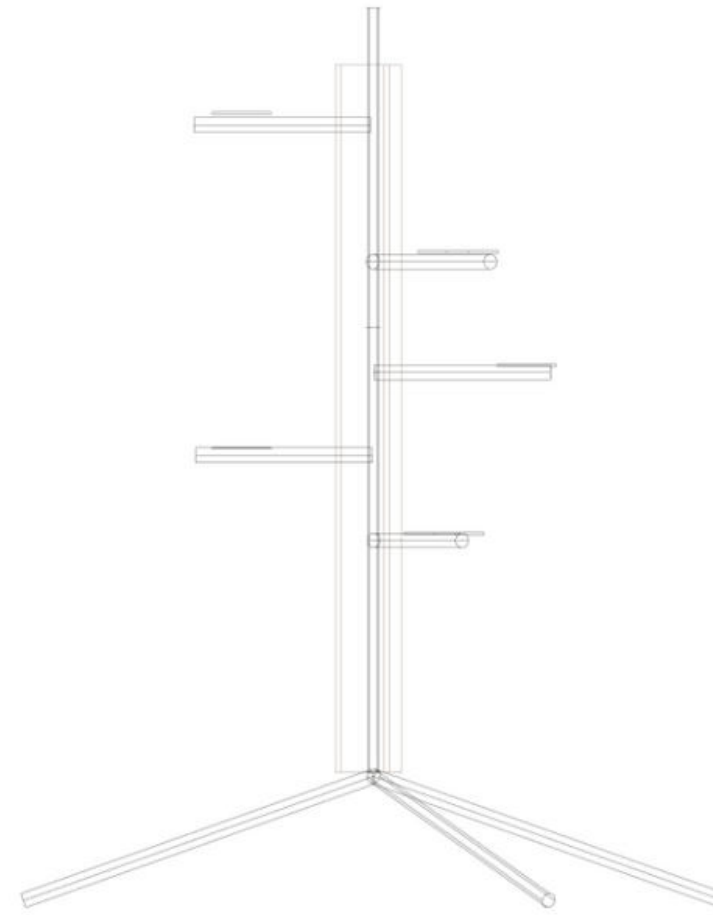

JEDNOTLIVÉ STOJANY

VELKÁ BRITÁNIE (1. 322 km)

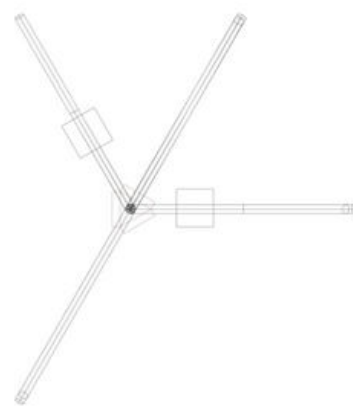
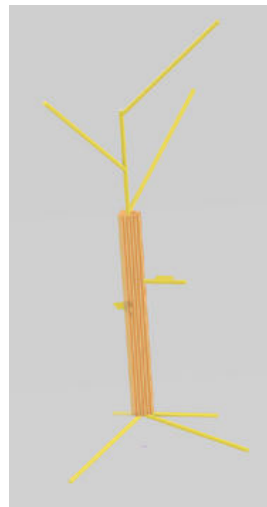
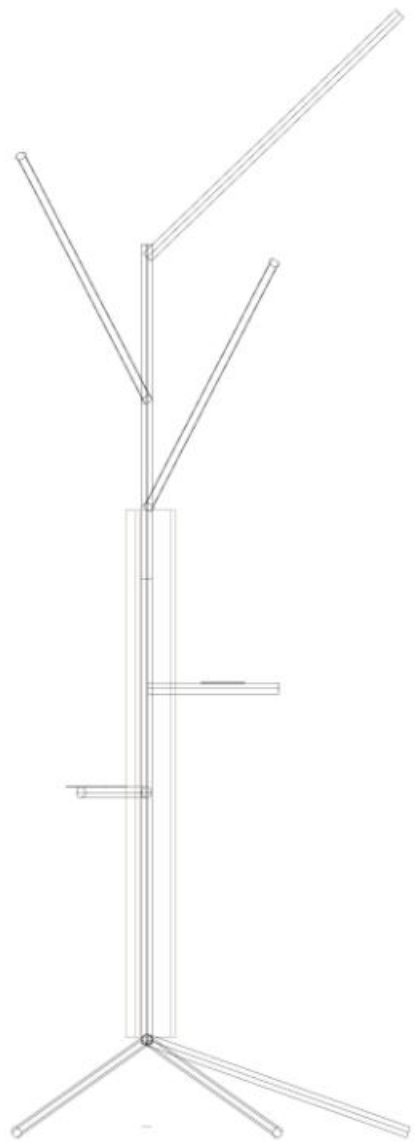

NORSKO (1. 224 km)

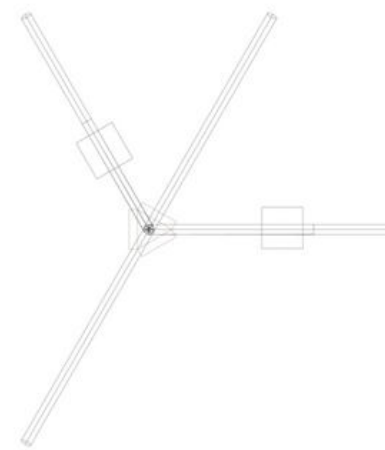
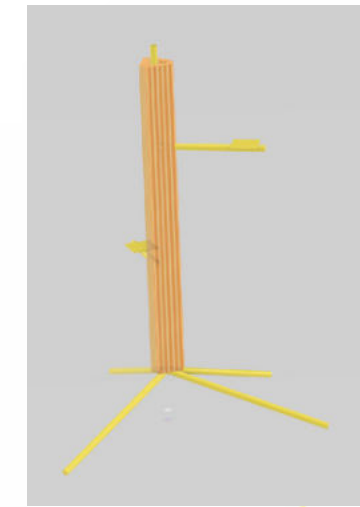
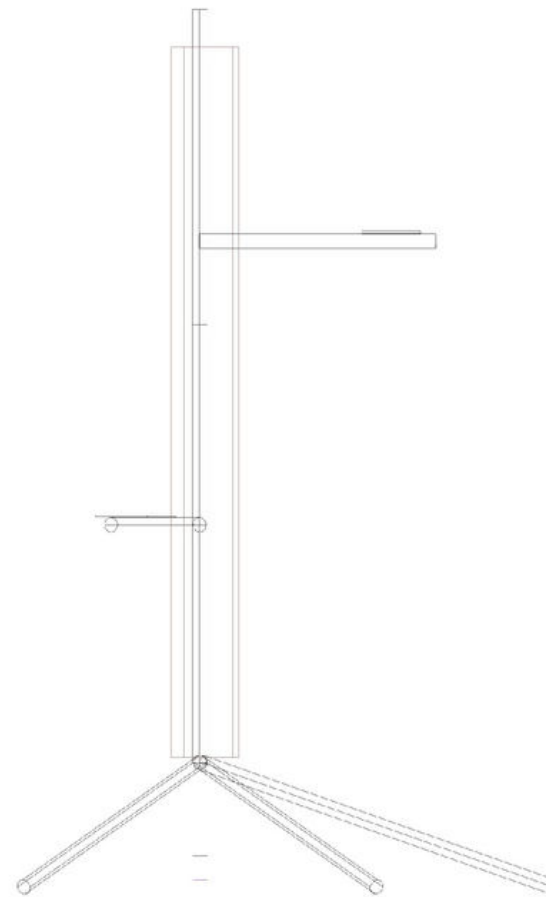

JEDNOTLIVÉ STOJANY

FRANCIE (1. 054 km)

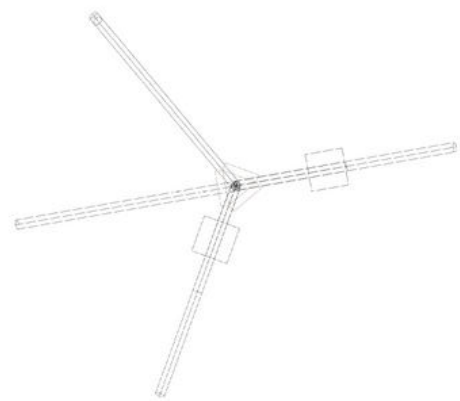
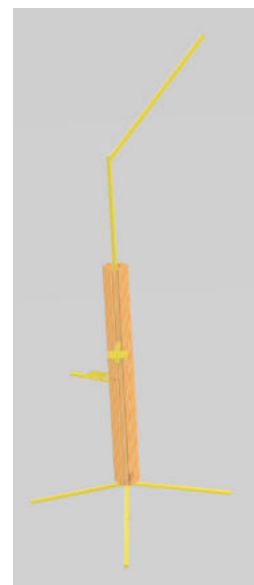
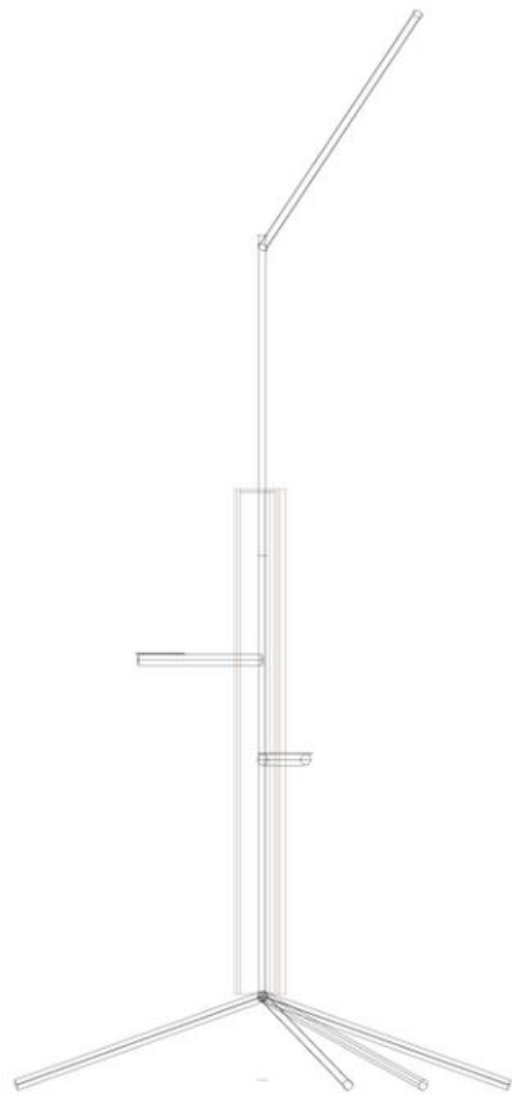

ŠPANĚLSKO (1. 840 km)

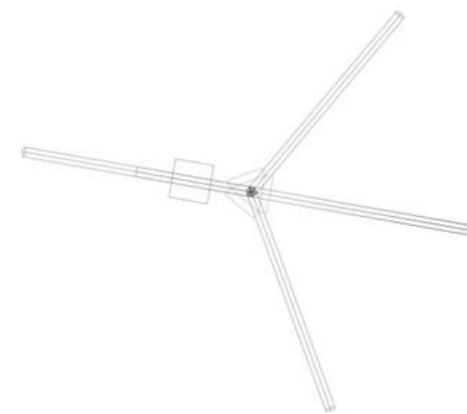
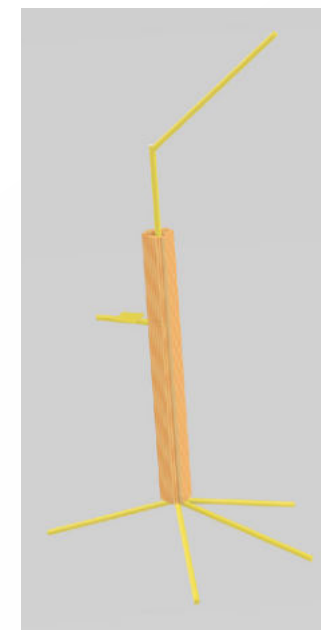

JEDNOTLIVÉ STOJANY

ŘECKO (1. 317 km)

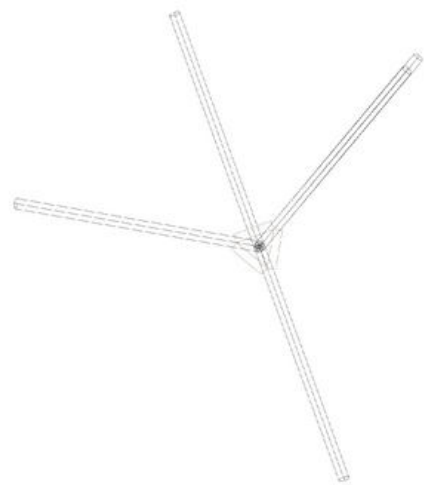
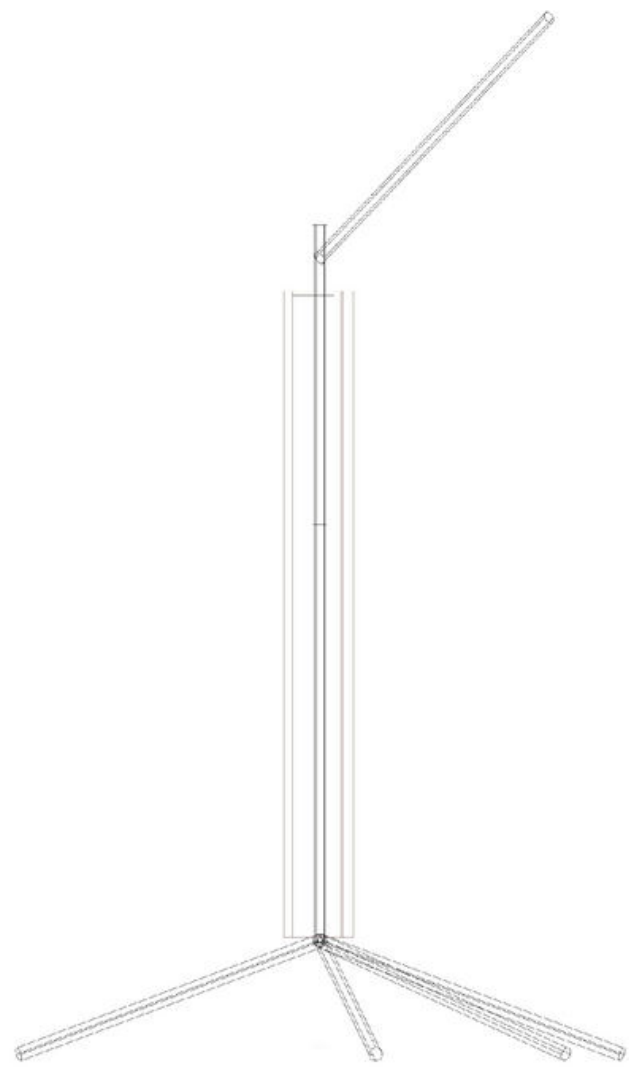

EGYPT (2. 836 km)

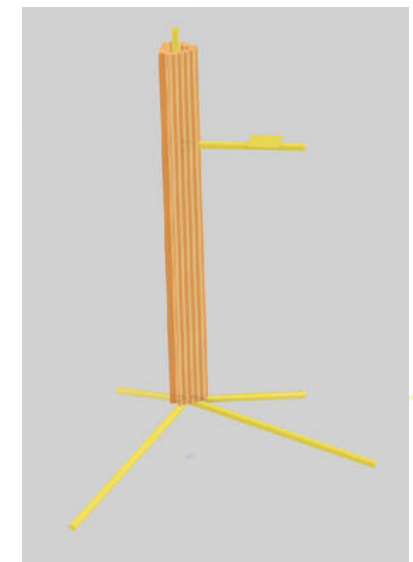
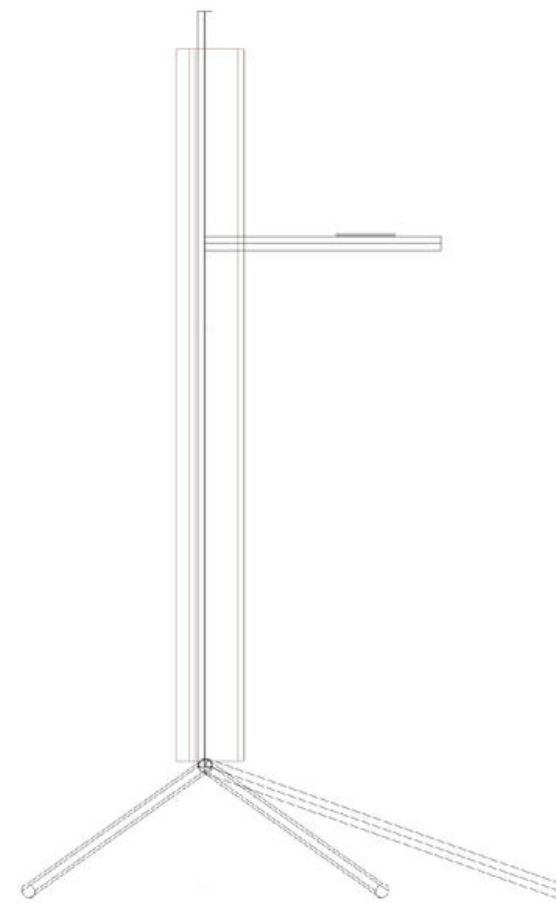

JEDNOTLIVÉ STOJANY

SPOJENÉ ARABSKÉ EMIRÁTY (4. 471 km)

JORDÁNSKO (2. 722 km)

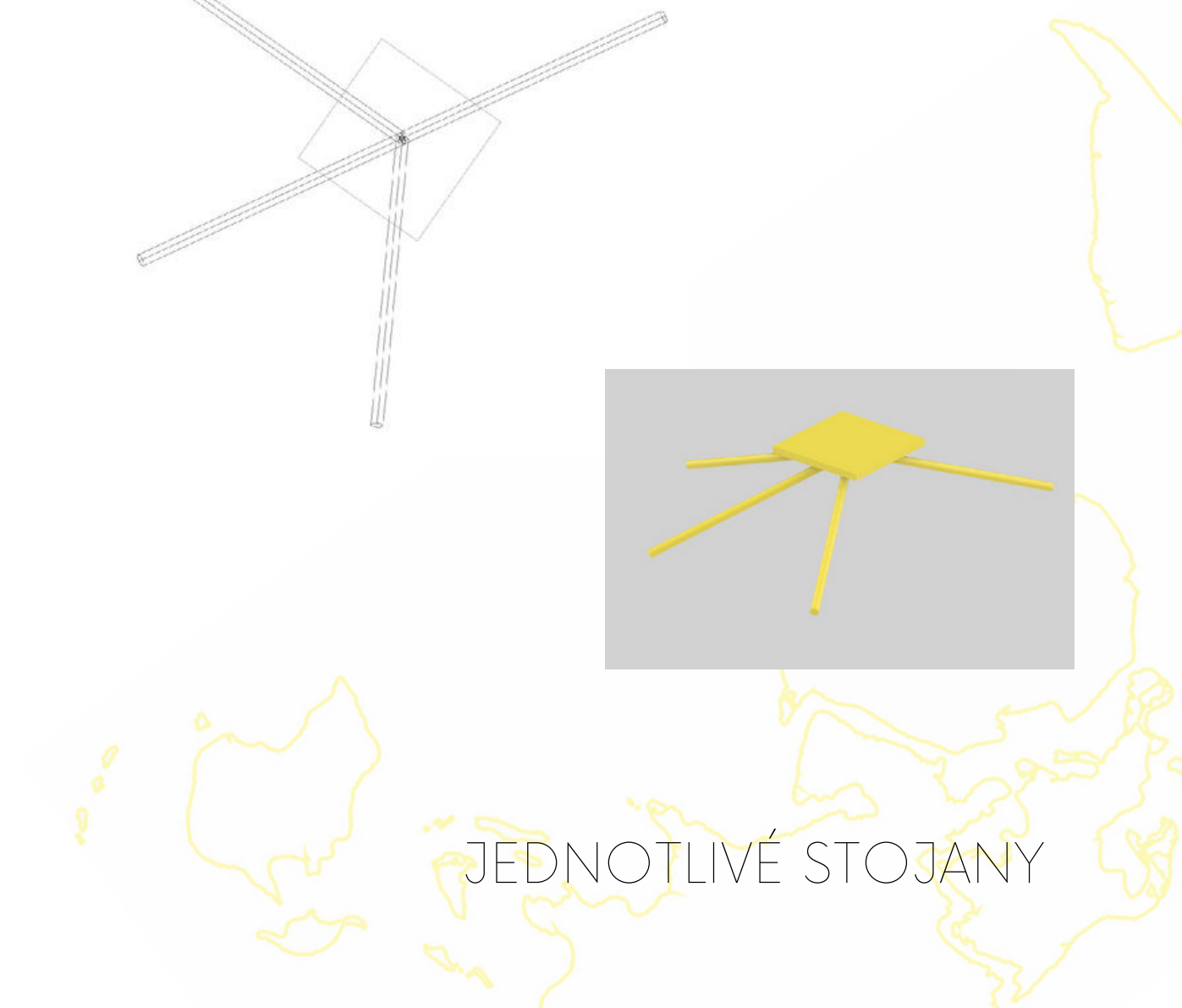
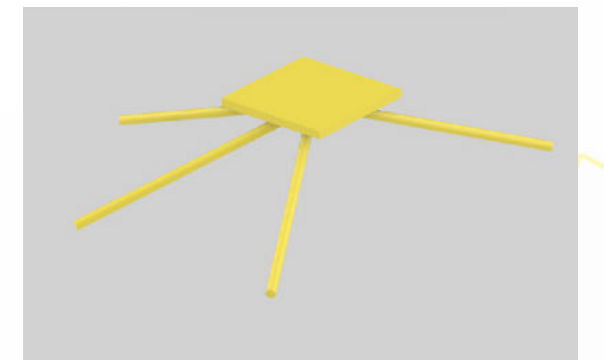
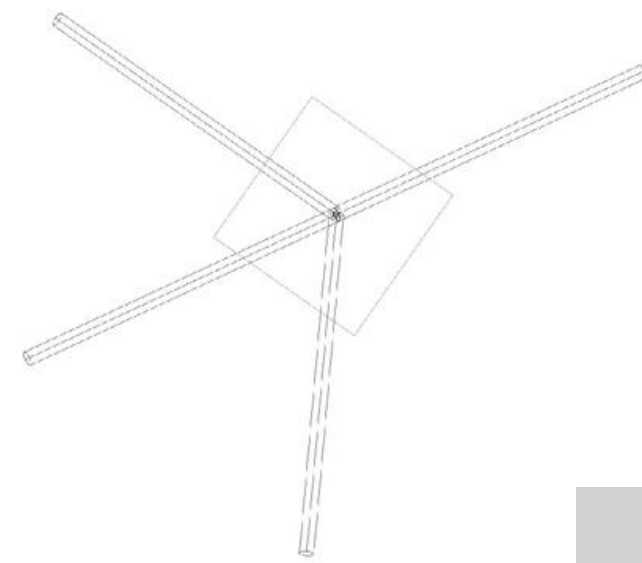
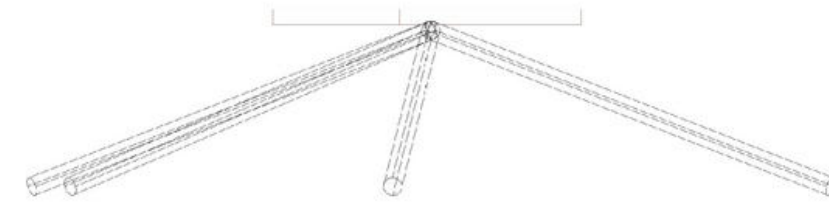
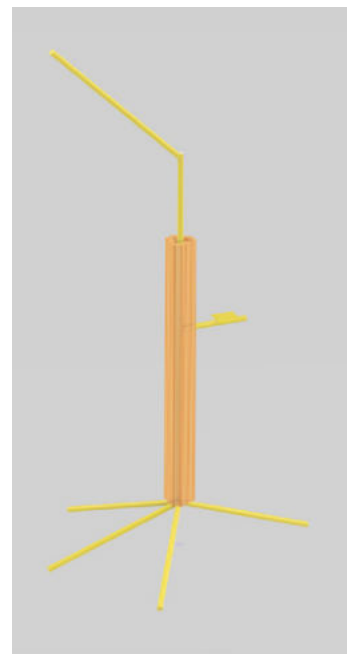
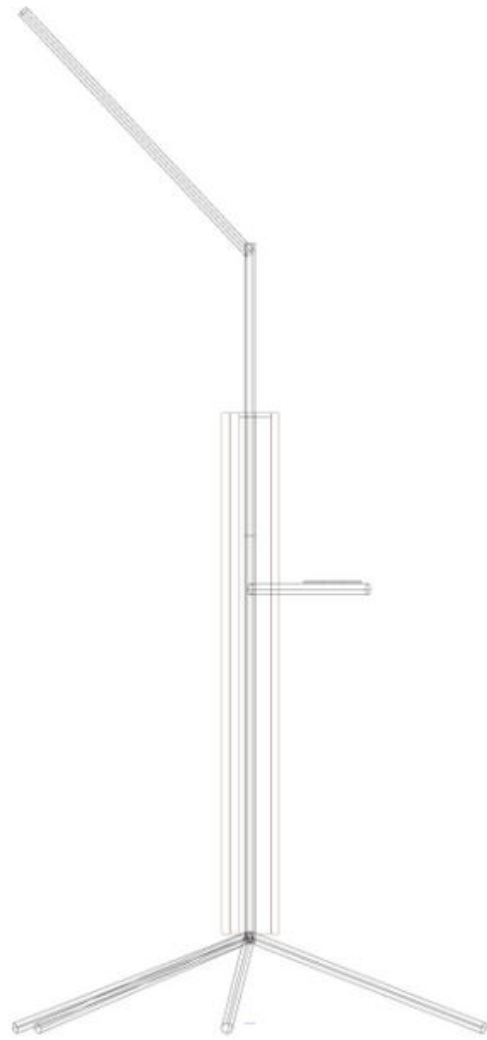

JEDNOTLIVÉ STOJANY

BRAZÍLIE (9. 465 km)

USA (8. 133 km)

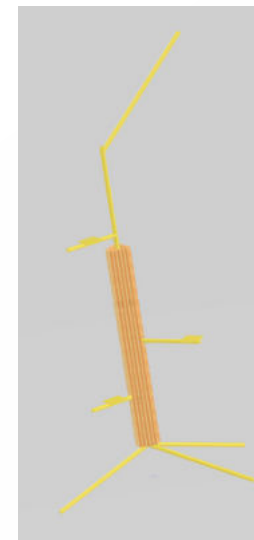
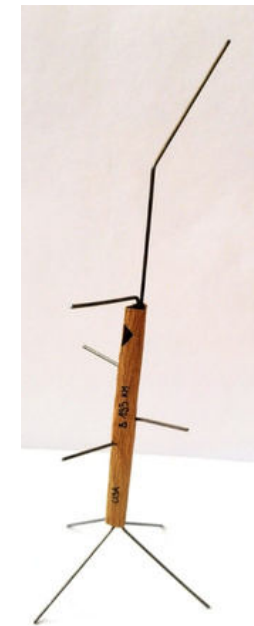
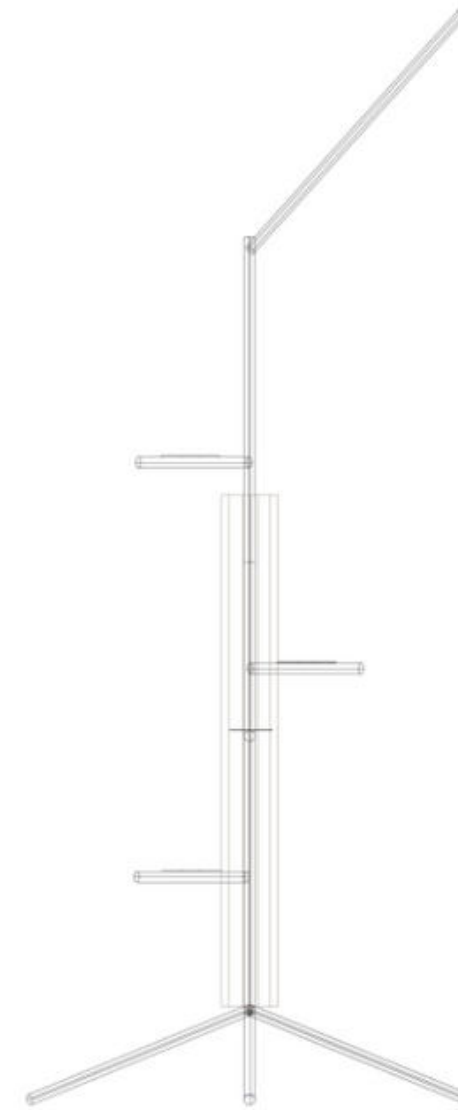
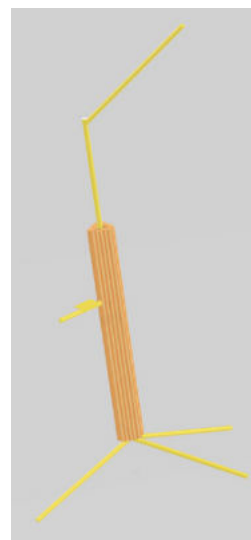
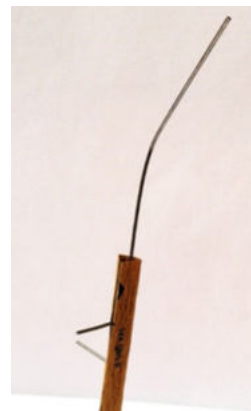

JEDNOTLIVÉ STOJANY

ARGENTINA (12. 114 km)

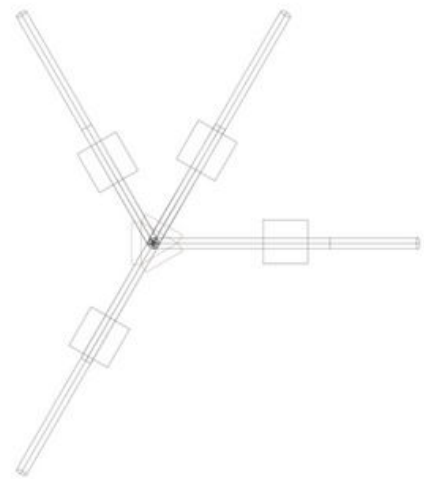
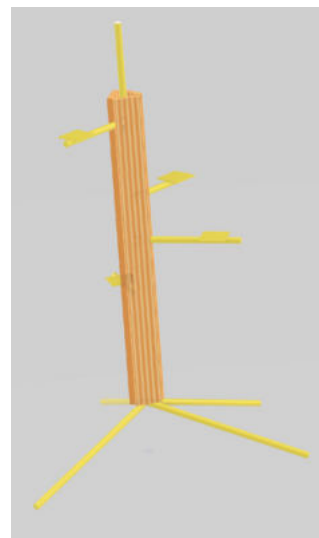
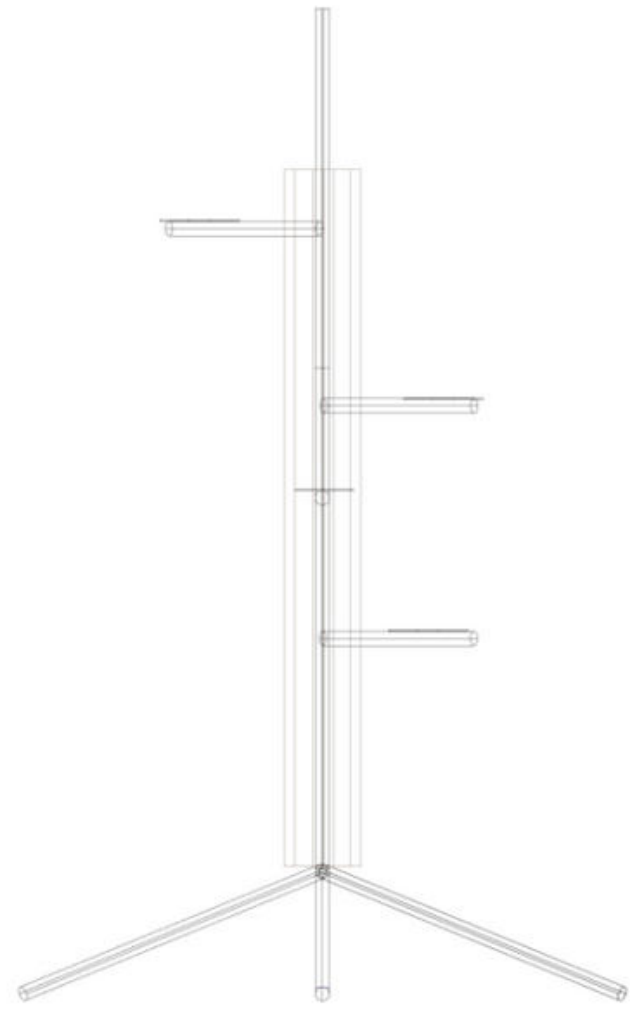

URUGUAY (11. 547 km)

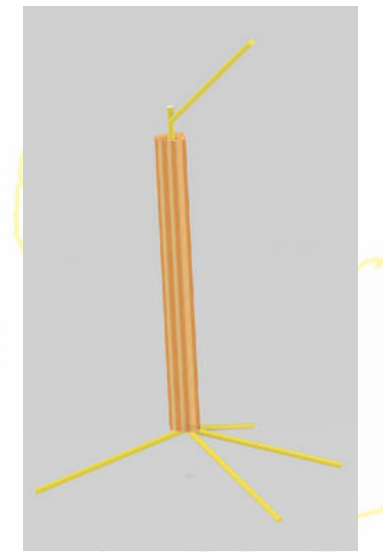
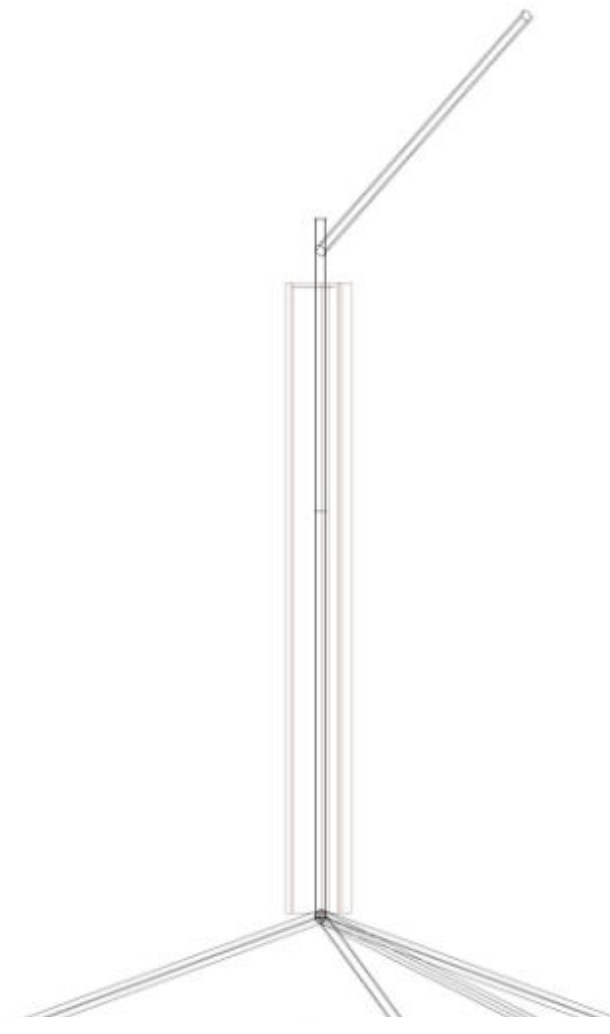

JEDNOTLIVÉ STOJANY

JIŽNÍ KOREA (8. 377 km)

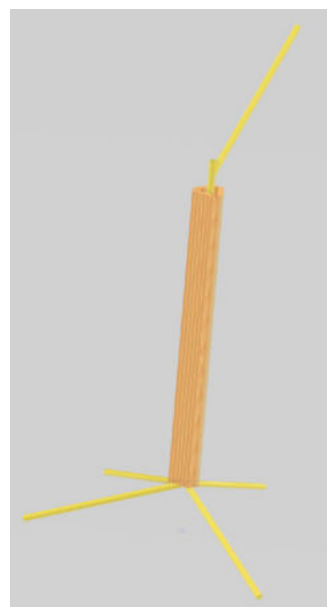

JEDNOTLIVÉ STOJANY

Roxor



Modřín - masiv



Ocelová tyč



MATERIÁLOVÉ A BAREVNÉ ŘEŠENÍ

ŠIPKA určující směr k České republice



VZDÁLENOST daného státu od České republiky

1 322 km



NÁZEV státu

VELKA BRITANIE



POPIS - název stavby, architekt, město

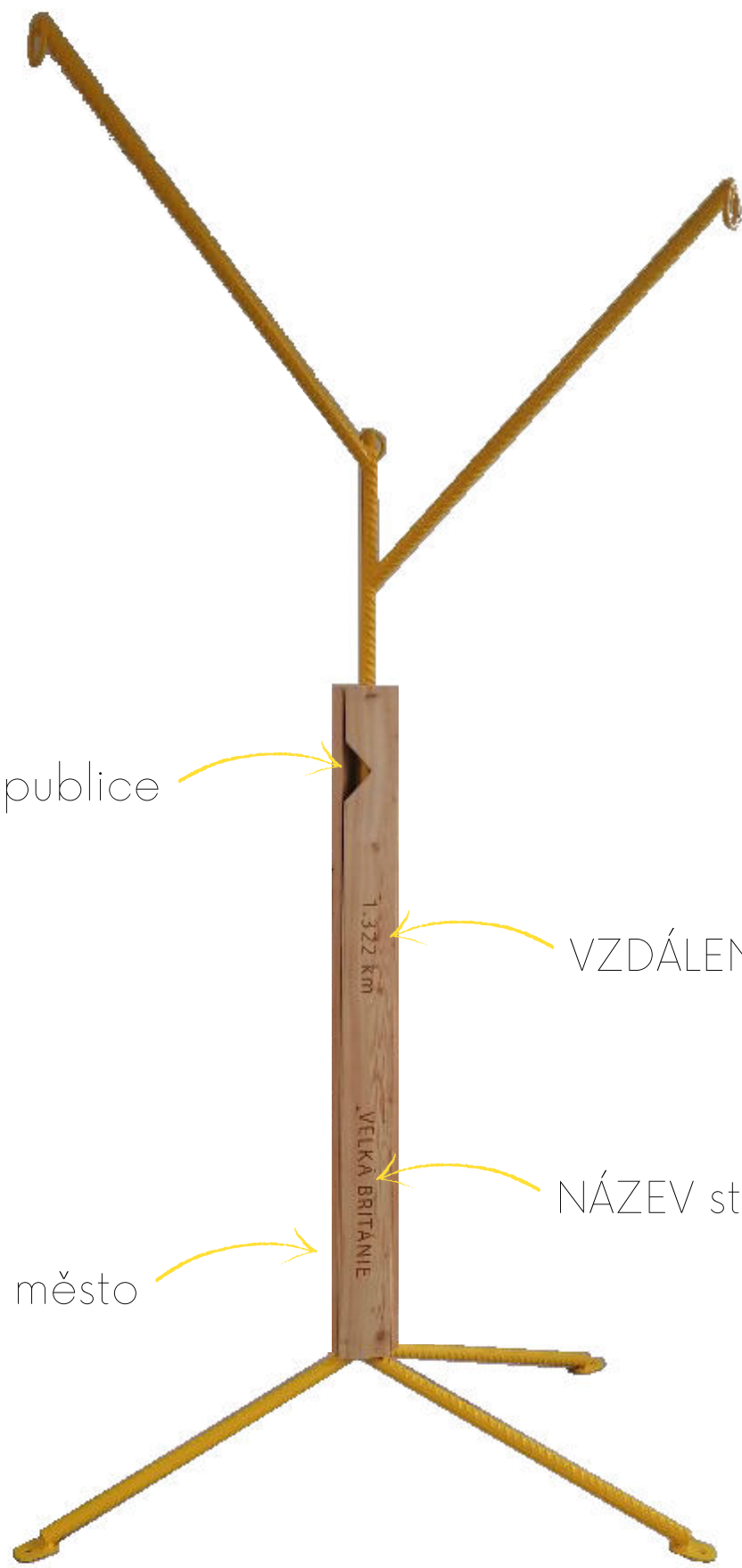

POPIS STOJANU



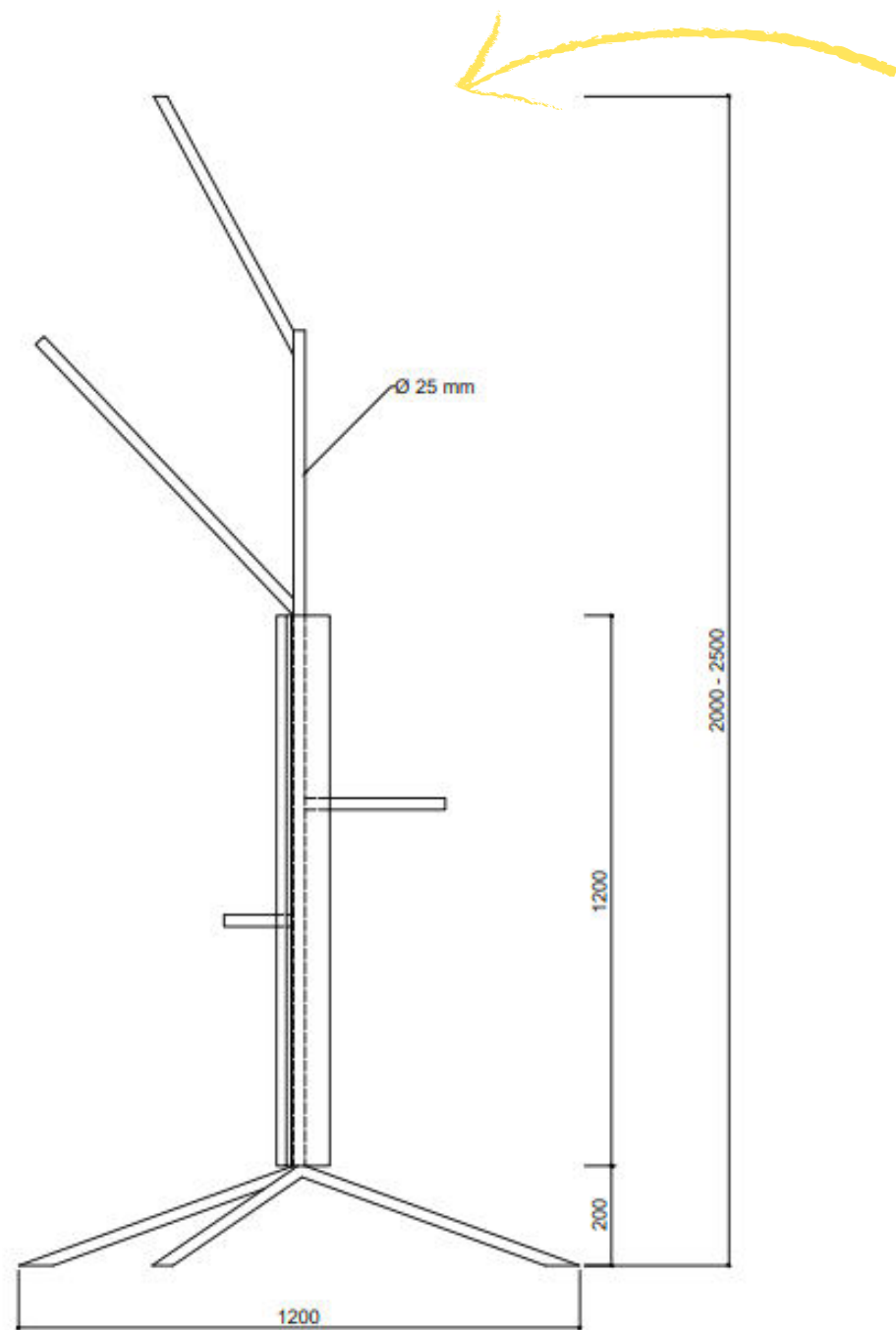

Zavěšení budek - provrtání tyče, ocelová lanka

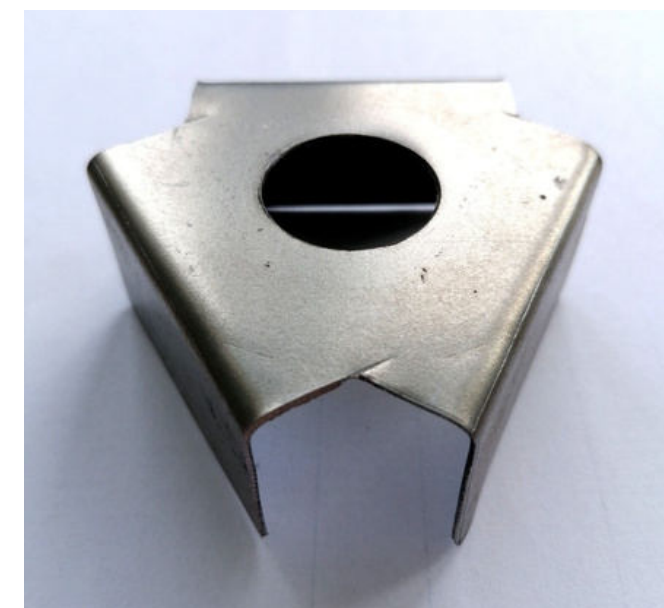
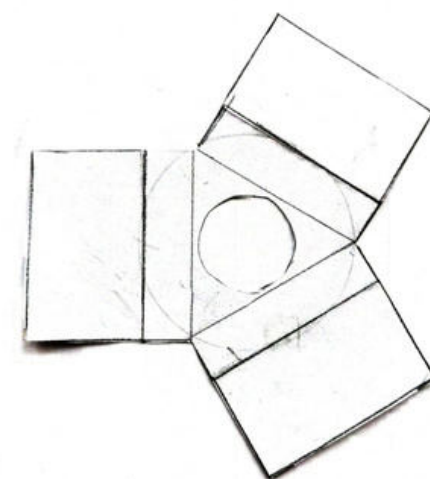

Nedemontovatelný způsob uchycení - provrtání samořeznými vruty

ZPŮSOB UCHYCENÍ PRKEN



Demontovatelný způsob uchycení - příchytky na trubky \varnothing 25 mm

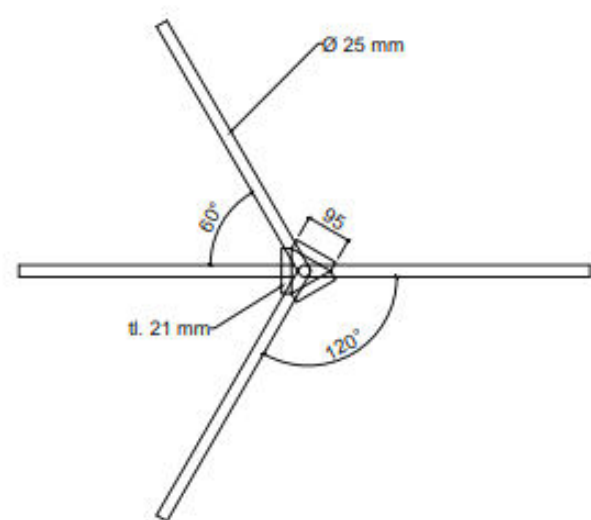

PODNOŽ - aretovací body na vyrovnání

TEHNICKÁ STRÁNKA

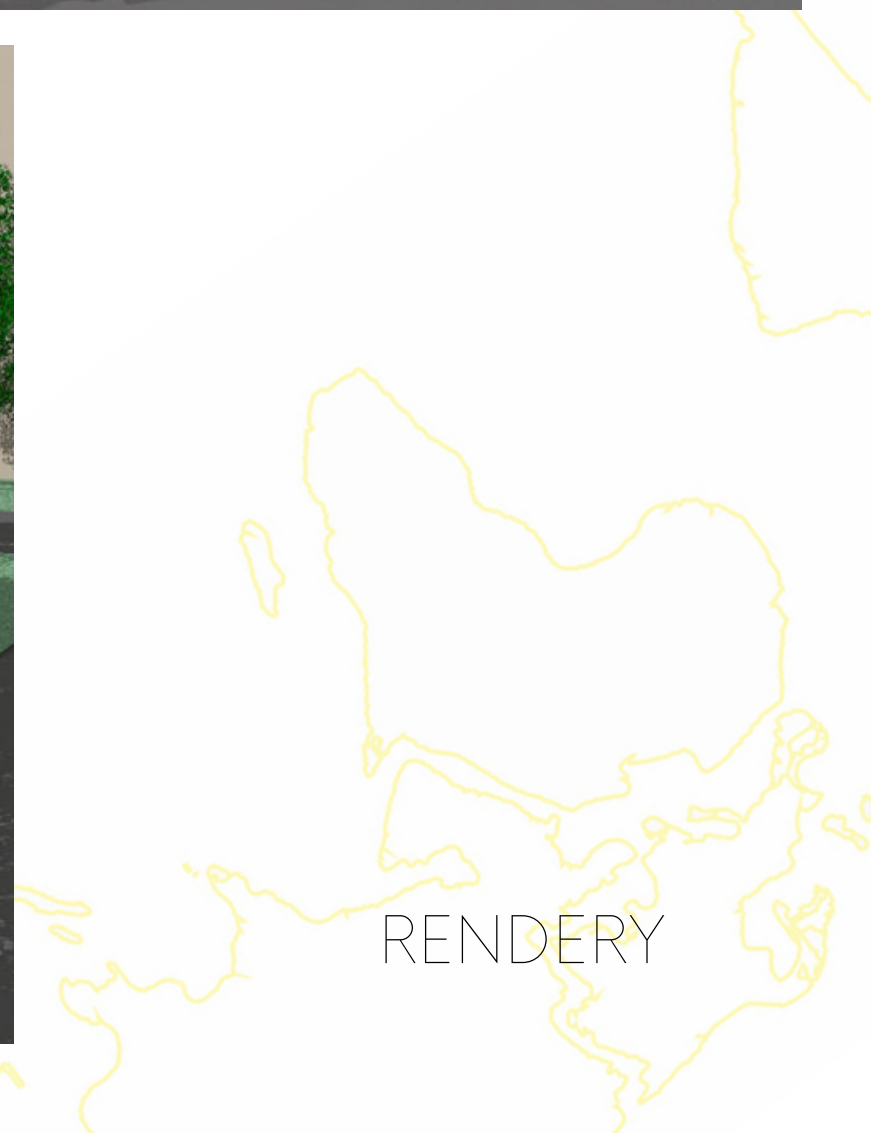

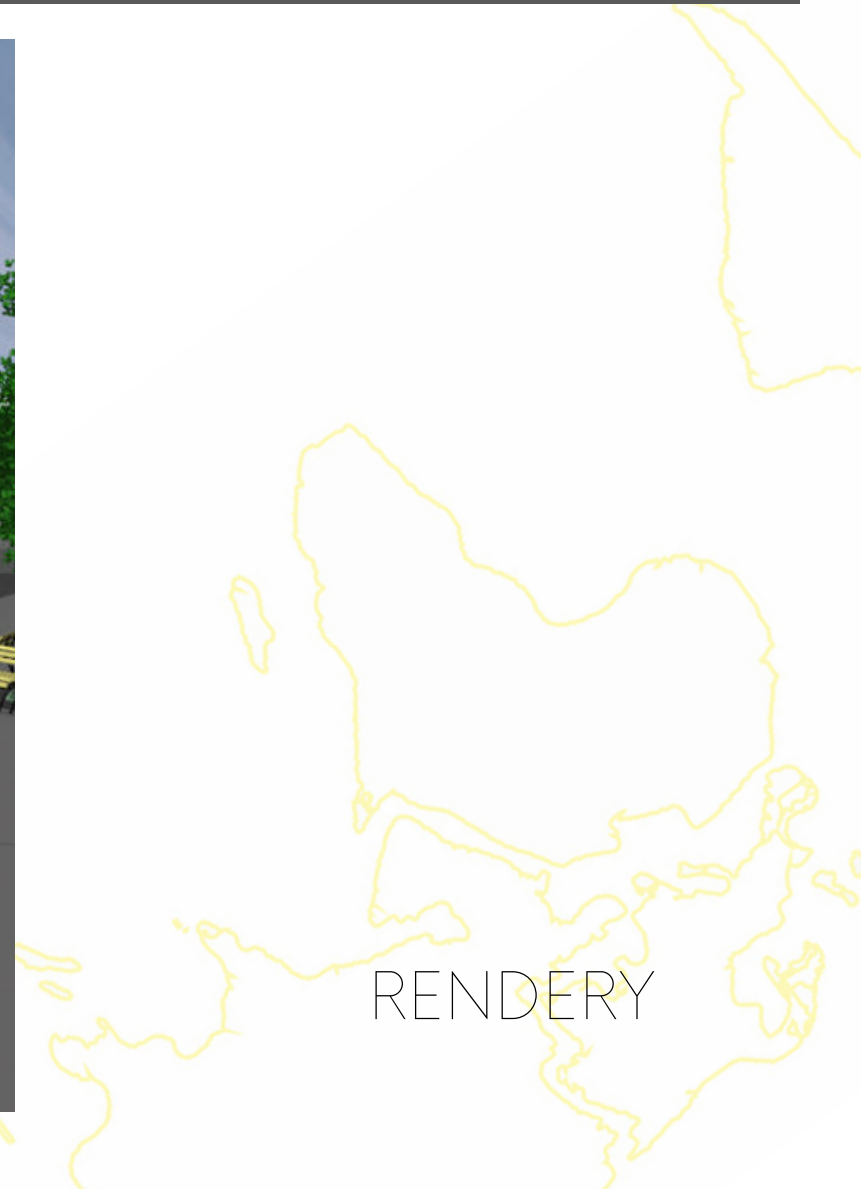
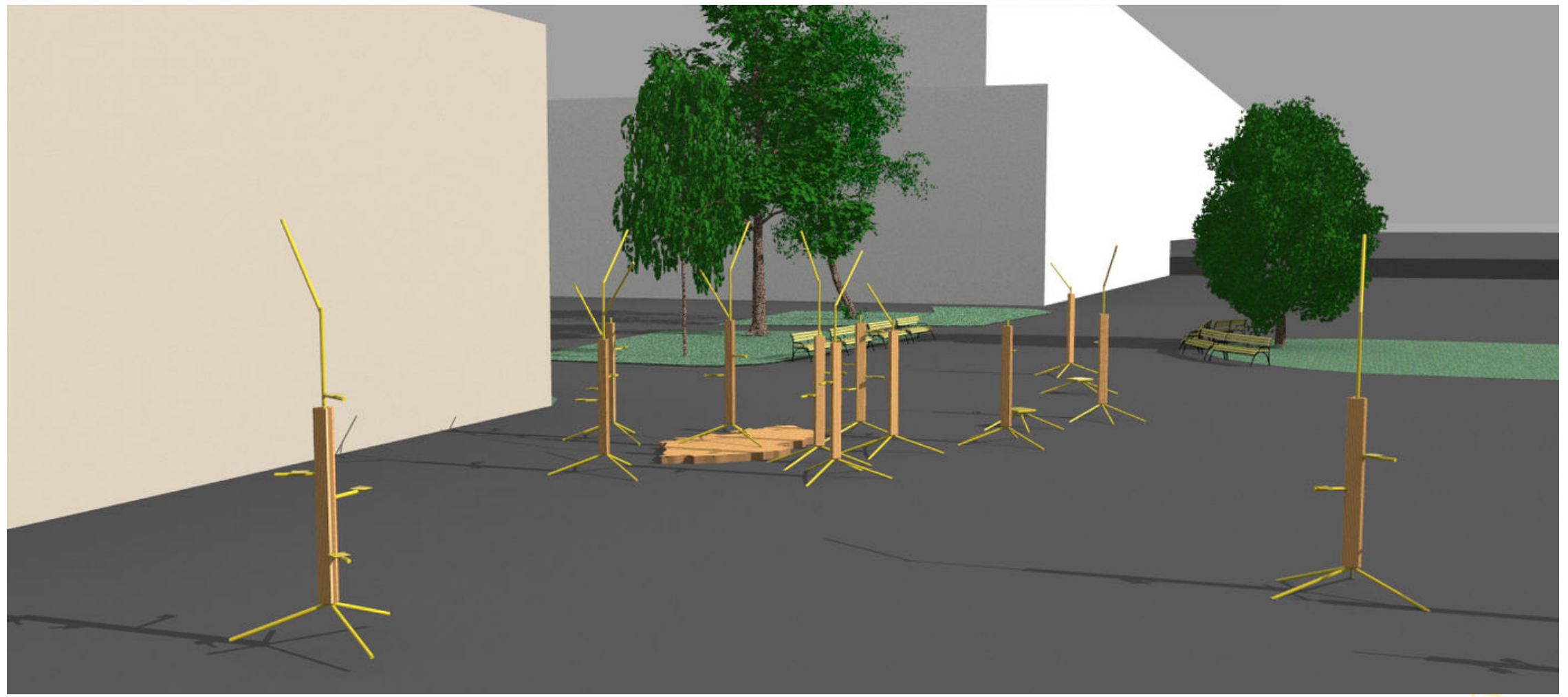

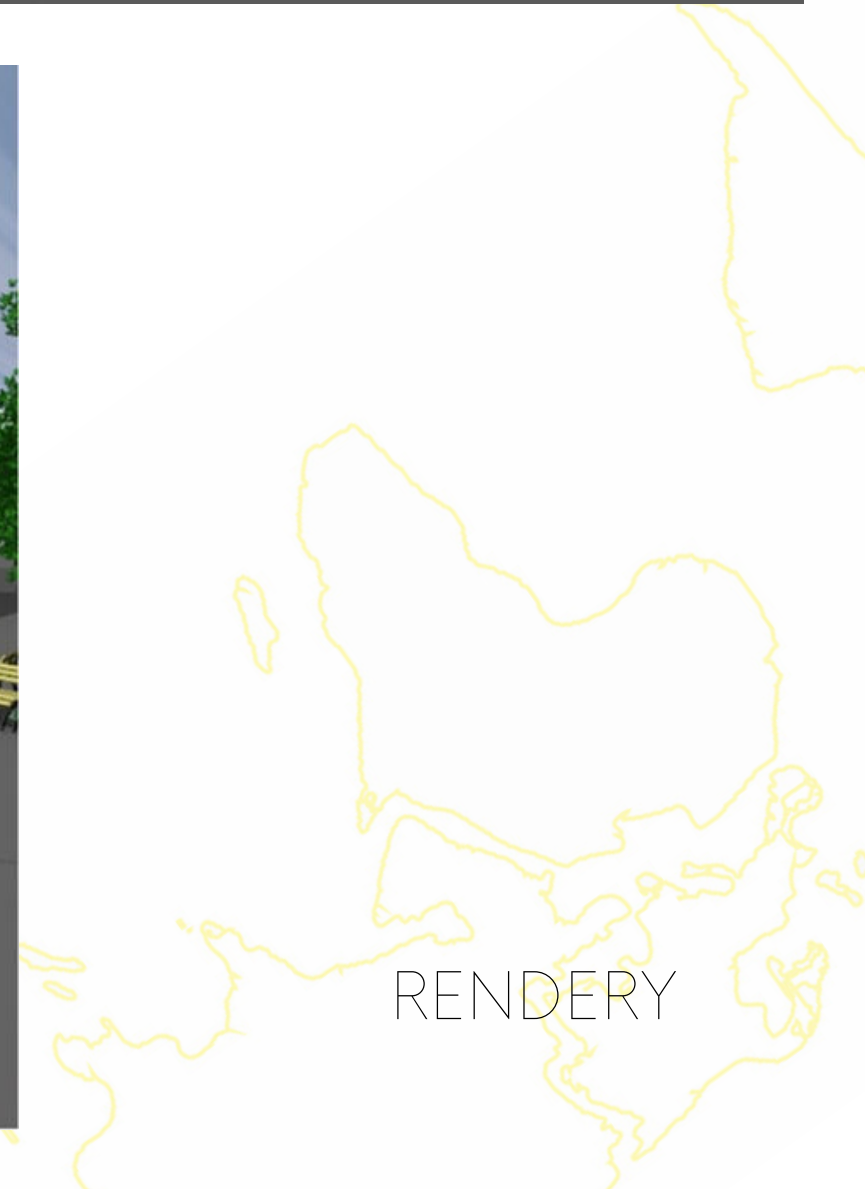
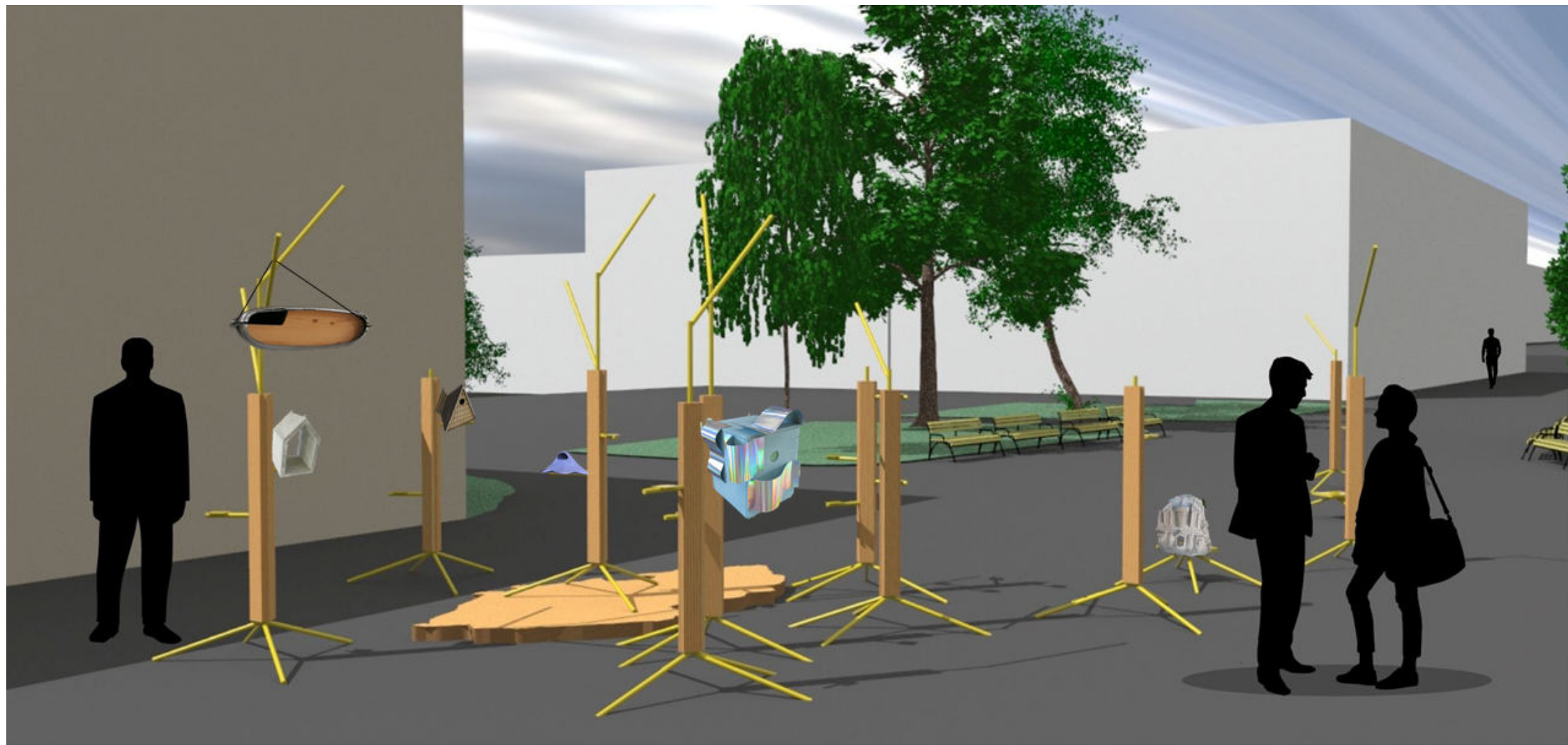



VIZUALIZACE V REÁLNÝCH PODMÍNKÁCH



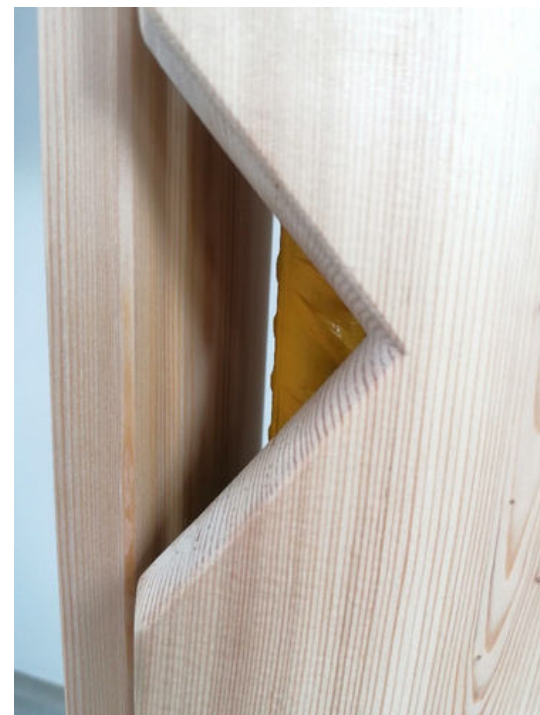

PROTOTYP



PROTOTYP



